

F-5400

THERMAL MASS FLOW SENSOR Installation and Operation Guide



This publication must be read in its entirety before performing any operation. Failure to understand and follow these instructions could result in serious personal injury and/or damage to the equipment. Should this equipment require repair or adjustment beyond the procedures given herein, contact the factory at:

ONICON
11451 Belcher Road South
Largo, FL 33773
Telephone: 727-447-6140
Email: sales@onicon.com

Download Technical Data Sheets from our website:
www.onicon.com

ONICON believes that the information provided herein is accurate; however, be advised that the information contained herein is NOT a guarantee for satisfactory results. Specifically, this information is neither a warranty nor guarantee, expressed or implied, regarding performance, merchantability, fitness, or any other matter with respect to the products; nor recommendation for the use of the product/process information in conflict with any patent. Please note that ONICON reserves the right to change and/or improve the product design and specification without notice.



ONICON F-5400 Manuals:

- **ONICON F-5000 View™ Manual**

All ONICON Manuals and software available in English only.

SAFETY INFORMATION

This meter was calibrated at the factory before shipment. To ensure correct use of the meter, please read this manual thoroughly.

Regarding this Manual:

- This manual should be passed on to the end user.
- Before use, read this manual thoroughly to comprehend its contents.
- The contents of this manual may be changed without prior notice.
- All rights reserved. No part of this manual may be reproduced in any form without ONICON’s written permission.
- ONICON makes no warranty of any kind with regard to this material, including, but not limited to, implied warranties of merchantability and suitability for a particular purpose.
- All reasonable effort has been made to ensure the accuracy of the contents of this manual. However, if any errors are found, please inform ONICON.
- ONICON assumes no responsibilities for this product except as stated in the warranty.
- If the customer or any third party is harmed by the use of this product, ONICON assumes no responsibility for any such harm owing to any defects in the product which were not predictable, or for any indirect damages.

Safety Precautions:

The following general safety precautions must be observed during all phases of installation, operation, service, and repair of this product. Failure to comply with these precautions or with specific WARNINGS given elsewhere in this manual violates safety standards of design, manufacture, and intended use of the product. ONICON Incorporated assumes no liability for the customer’s failure to comply with these requirements. If this product is used in a manner not specified in this manual, the protection provided by this product may be impaired.

The following symbols are used in this manual:



	<p style="text-align: center;">WARNING</p> <p>Messages identified as WARNING contain information regarding the personal safety of individuals involved in the installation, operation or service of this product.</p>
	<p style="text-align: center;">CAUTION</p> <p>Messages identified as CAUTION contain information regarding the potential damage to the product or other ancillary products.</p>
	<p style="text-align: center;">IMPORTANT NOTICE</p> <p>Messages identified as IMPORTANT NOTICE contain information critical to the proper operation of the product.</p>

TABLE OF CONTENTS

- 1.0 INTRODUCTION** 5
 - 1.1 Quick Start Guide..... 5

- 2.0 INSTALLATION: GENERAL** 9
 - 2.1 Instructions for Insertion Flow Meter Lateral Placement 10
 - 2.2 Installation Hardware 11
 - 2.3 Flow Conditioners..... 12
 - 2.4 Sensor Orientation Direction of Flow 13
 - 2.5 Sensor Element Alignment..... 14

- 3.0 WIRING** 20
 - 3.1 Wiring Instructions..... 20
 - 3.2 Power Wiring 21
 - 3.3 Grounding 21
 - 3.4 Signal Wiring 21
 - 3.5 Power Input Requirements: 12 to 28VDC Supply..... 21
 - 3.6 4-20mA Output Wiring: Customer-Supplied Power Source 22
 - 3.7 4-20mA Output Wiring: Loop Power Provided by F-5400 23
 - 3.8 Pulse/Alarm Output Wiring: Customer Supplied Power Source 24
 - 3.9 Pulse/Alarm Output Wiring: Power Provided by F-5400..... 25

- 4.0 OPERATION: START-UP** 26
 - 4.1 Start Up Sequence..... 26
 - 4.2 Programming and Configuring Flow Meter and Flow Meter Settings 26
 - 4.3 Access to Electronics 27
 - 4.4 Broken or Damaged Probe 27
 - 4.5 Flow Calibration..... 27
 - 4.6 Fuse Replacement..... 27
 - 4.7 Sensor Cleaning..... 27



- 5.0 TROUBLESHOOTING** 28
 - 5.1 LED Indicators 28
 - 5.2 Installation Problems..... 29
 - 5.3 Alarm Codes 30

- APPENDICES** 31
 - A Specifications..... 31
 - B Dimensions..... 34
 - C Warranty 37
 - D Returning Your Meter..... 38

SECTION 1.0: INTRODUCTION

1.1 QUICK START GUIDE

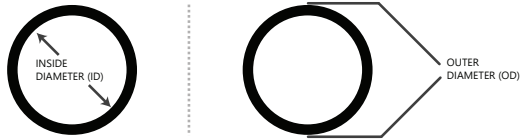
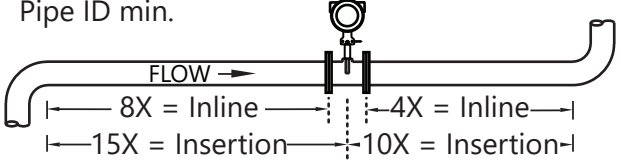
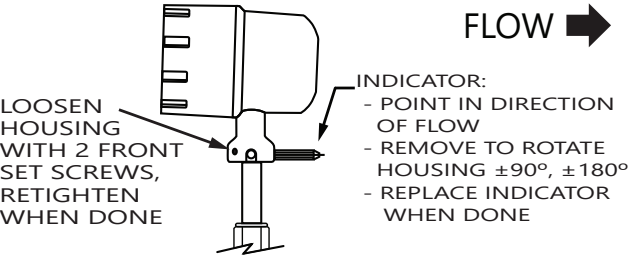
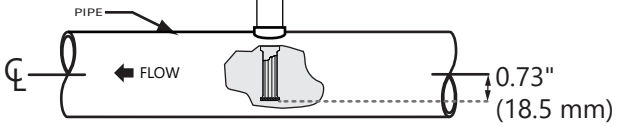
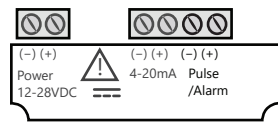
Use the table and images below as a guide while using the worksheet on the next page to record your notes. **Note:** Please read the entire Quick Start procedure before beginning installation.

<p>1.</p>	<p>Record inside diameter (ID). Ensure the actual pipe ID matches the pipe ID shown on the factory calibration certificate. If IDs do not match, refer to the F-5000 View Manual for further instructions on how to correct this value.</p>	
<p>2.</p>	<p>Record upstream and downstream straight-pipe requirements based on tables for insertion (p. 13) and inline (p.19).</p>	<p>Pipe ID min.</p> 
<p>3.</p>	<p>a. The Flow Direction Indicator must point in the direction of flow. b. The Indicator can also be used to change the orientation of the housing for better access to the wiring. Note that the 2 set screws must be loosened before the housing will turn. (refer to p. 13 for more information)</p>	 <p>INDICATOR:</p> <ul style="list-style-type: none"> - POINT IN DIRECTION OF FLOW - REMOVE TO ROTATE HOUSING ±90°, ±180° - REPLACE INDICATOR WHEN DONE
<p>4.</p>	<p>Ensure correct probe depth setting. If using 1½" size pipe, please see note on p. 15.</p>	
<p>5.</p>	<p>Ensure power wiring, pulse, and 4-20mA wiring properly connected (refer to p. 21 - p. 25 for more information)</p>	
<p>6.</p>	<p>Power on the flow meter</p>	
<p>7.</p>	<p>Check the remaining flow meter settings by accessing the meter settings by using the F-5000 View software tool. Record the settings in the spaces given for items A-D on the following page.</p>	

Before powering on your meter, use this worksheet to record your notes.

	Item to Verify	Serial Number:	Serial Number:	Serial Number:	Serial Number:
1.	What is the Pipe ID?	ID =	ID =	ID =	ID =
2.	Calculate the Upstream/ Downstream straight-pipe requirements	UP = DN =	UP = DN =	UP = DN =	UP = DN =
3.	a. Is the flow indicator pointed in direction of flow? b. Must the housing be rotated for easy wiring?	Y / N Y / N	Y / N Y / N	Y / N Y / N	Y / N Y / N
4.	Is the probe depth setting correct?	Y / N	Y / N	Y / N	Y / N
5.	Verify proper power wiring setup				
6.	Verify proper output wiring setup				

After powering on your meter, check items A - D below by accessing the meter settings through the F-5000 View software tool.

A.	Which flow units have been set in meter? (SCFH, KG/H, etc.)				
B.	Correct values for reference temperature and pressure?	Y / N	Y / N	Y / N	Y / N
C.	Confirm the pipe ID listed above same as "Pipe_id="				
D.	Verify the 4mA and 20mA meter settings	4mA = 20mA =	4mA = 20mA =	4mA = 20mA =	4mA = 20mA =

Your Notes:

If you are experiencing any problems after completing this procedure, please call the ONICON Service Department at 727-447-6140 to review the information.

WELCOME

Thank you for purchasing the Model F-5400 Thermal Gas Mass Flow Meter from ONICON. The Model F-5400 is one of the most technically advanced flow meters in the world. An extensive engineering effort has been invested to deliver advanced features, accurate measurement performance, and outstanding reliability.

This Instruction Manual contains the electrical and mechanical installation instructions as well as details for programming, maintaining, and troubleshooting the meter. This manual is divided into the following sections: Introduction, Installation, Wiring, Operation, Maintenance, Troubleshooting, Appendices, Glossary, and Index.

PRODUCT DESCRIPTION

Theory of Operation

The Model F-5400 is an innovative Thermal Mass Gas Flow Meter and Temperature Transmitter. It is microprocessor-based and field programmable. The F-5400 thermal sensor operates on the law that gases absorb heat. A heated sensor placed in an air or gas stream transfers heat in proportion to the stream's mass velocity. There are two sensor elements. One sensor element detects the gas temperature and a second element is maintained at a constant temperature above the gas temperature. The energy applied to the heated sensor to maintain a constant temperature differential (constant ΔT) is directly proportional to the mass flow velocity. The F-5400 flow meter maintains accurate flow measurement over a large temperature and pressure range.

Mass Flow

The Model F-5400 measures mass flow; an advantage over other flow meters which measure volumetric flow. Volumetric flow is incomplete because temperature and pressure are unknown and must be measured separately. For example, the mass flow of a gas depends on its temperature and pressure. As temperature and pressure changes, the gas volume changes but not its mass. Therefore a device measuring mass flow is independent of temperature and pressure changes. The Model F-5400 provides a direct measurement of gas flow in Mass units (kg/hr, lb/hr), standard units (SCFM, SLPM) or normal units (NM³/hr, NLPM) with no additional temperature or pressure measurements required.

DDC-Sensor™ Technology

The ONICON DDC-Sensor is a new state of the art sensor technology used in the ONICON Model F-5400 Thermal Gas Flow Meter. The DDC-Sensor™, a Direct Digitally Controlled sensor, is unlike other thermal flow sensors available on the market. Instead of using traditional analog circuitry, the DDC-Sensor™ is interfaced directly to the F-5400 microprocessor for more control, precision, and programmability. The DDC-Sensor™ quickly and accurately responds to changes in process variables by utilizing the microprocessor to determine mass flow rate, totalized flow, and temperature.

Flow Calibration

The ONICON Calibration Lab maintains instrument calibration data on every flow meter. Calibration files include details on process conditions, customer gas, line size, and other information. All NIST-traceable equipment utilized for the calibration procedure is identified on the Calibration Certificate, which is sent with every flow meter.

Calibration records include details on process conditions, calibration fluid, line size, and other information. ALL NIST-traceable equipment utilized for the calibration procedure is identified, as is the calibration history of all reference equipment.

In addition to the Calibration Certificate, a certified flow table that correlates current outputs with scaled units of flow is produced for each calibrated device.

I/O Description

The F-5400 features a galvanically isolated 4-20mA analog output and a second output for pulse. There is also a mini USB port for interfacing with a laptop or computer. The 4-20mA output can be configured for flow rate or process gas temperature and be scaled by the user. The pulse output can be used for pulse or alarm, is programmable to represent flow rate and can be scaled for units per pulse at a maximum pulse output frequency of 1Hz.

F-5000 View™ interfaces to the USB port and is a free PC-based software program that displays flow meter readings and permits flow meter configuration. The optional D-100 flow display provides a local indication of rate and total and a network interface for BACnet, MODBUS, LonWorks, JCI - N2 or Siemens-P1 FLN networks.



Note: The latest version of the F-5000 View software is available for download at <https://www.onicon.com/products/f-5400-series-thermal-mass-flow-meter>

USB Interface

The mini USB interface is a standard feature which allows communication with a PC to monitor readings and configure settings. F-5000 View, is a free application program from ONICON that connects to the USB interface and allows data monitoring, configuration setting, data logging to Excel, and an option to save and recall F-5400 configuration data.

SECTION 2.0: INSTALLATION: GENERAL

This section describes how to install the ONICON Model F-5400 Flow Meter and how to get started:

1. Determine lateral position on the pipe
2. Ensure correct orientation of the meter and check alignment of the sensor elements
3. Determine the installation depth of the probe
4. Tighten compression fitting to complete installation

Installation procedures must be performed using a combination of the end user's best engineering practices, in compliance with local codes, and manufacturer's recommendations.

General Precautions

The following general precautions should be observed:

1. Exercise care when handling the flow meter to avoid damaging the probe, sensor, or enclosure.
2. The enclosure cover must be closed except during installation or configuration.
3. Mounting F-5400 in direct sunlight can cause the temperature inside the enclosure to increase beyond design limits, resulting in reduced component life. It is recommended that a sunshade be installed to avoid direct sunlight (see maximum enclosure operating temperature specification on p. 33).
4. Ensure the flow direction indicator on the meter is in line with the direction of flow in the pipe.
5. Do not install the F-5400 enclosure near an igniter, igniter-controller or switching equipment.
6. Do not install an external power supply in a cabinet containing an igniter controller or switching equipment.
7. For accurate flow measurement: review flow meter placement instructions before installation to ensure a proper flow profile in the pipe.

2.1 INSTRUCTIONS FOR INSERTION FLOW METER LATERAL PLACEMENT

Install the Model F-5400 Insertion style flow meter so that it is far enough away from bends in the pipe, obstructions, or changes in line sizes to ensure a consistent flow profile. Review the straight run requirements table on p. 13.



IMPORTANT NOTE
The probe diameter is 3/4".

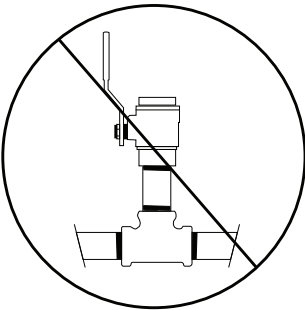
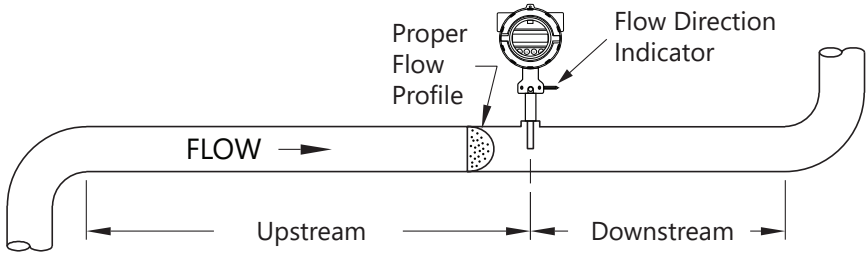

Do not substitute threaded tees for the welded branch outlet. Contact ONICON if you need installation

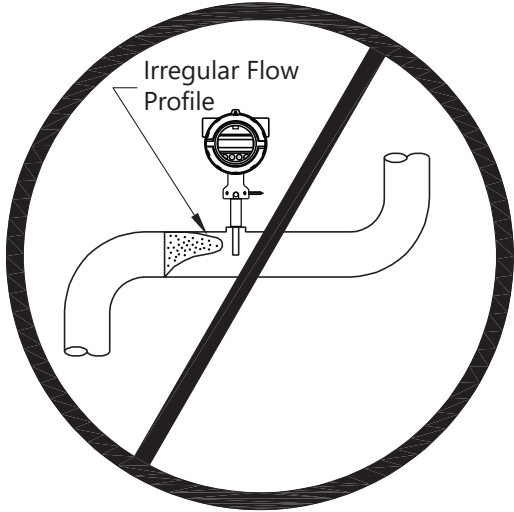

Fig. 2.1: Upstream and Downstream Pipe IDs for Insertion Meters



IMPORTANT NOTE
An irregular flow profile may affect sensor accuracy.

2.2 INSTALLATION HARDWARE

ONICON F-5400 Insertion Thermal Mass Flow Meters employ a process adapter fitting design that allows for insertion and removal without interrupting flow. To take advantage of this feature, the flow meter must be installed through an isolation valve. The installation must allow for sufficient overhead clearance to fully extract the meter, and a full 7/8" hole in the pipe wall is required to clear the sensor head and allow for insertion. Make sure that your valves and fittings are full port and at least 1" in actual internal diameter.

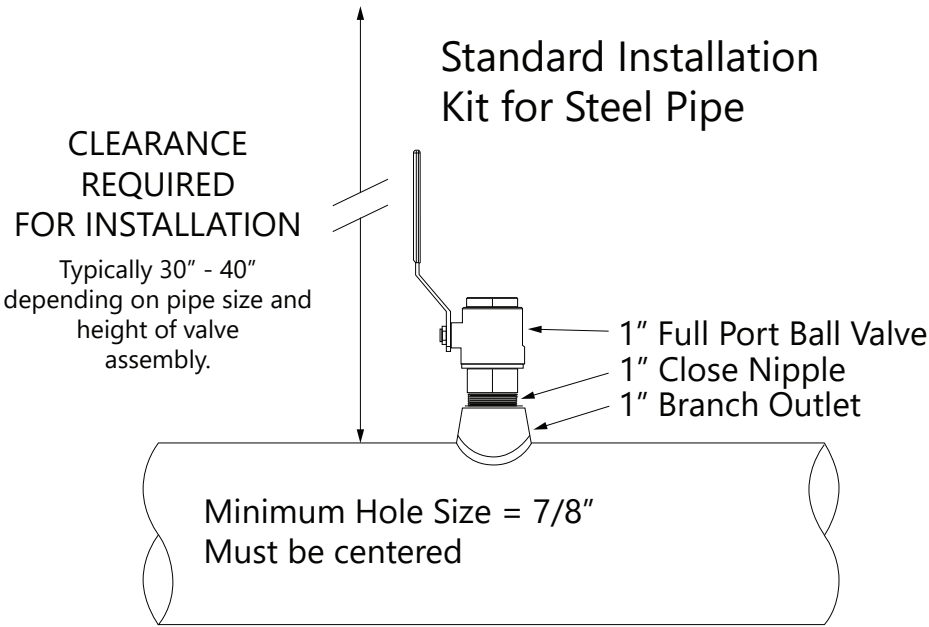

Fig. 2.2: Installation Requirements



CAUTION

ONICON insertion style flow meters must be installed through a valve assembly. Failure to do so negates the ability to remove the meter without shutting down and purging the system. It will also result in an excessive amount of stem protruding from the pipe. Excessive stem lengths unnecessarily expose the meter to incidental damage.



IMPORTANT NOTICE

Flow meters installed through oversized access holes will be subjected to undesirable turbulence that may affect the accuracy of the meter.

2.3 FLOW CONDITIONERS

Flow conditioners may be required when an insufficient straight run of pipe is available upstream of the proposed sensor location. ONICON provides flow conditioners as an optional accessory.

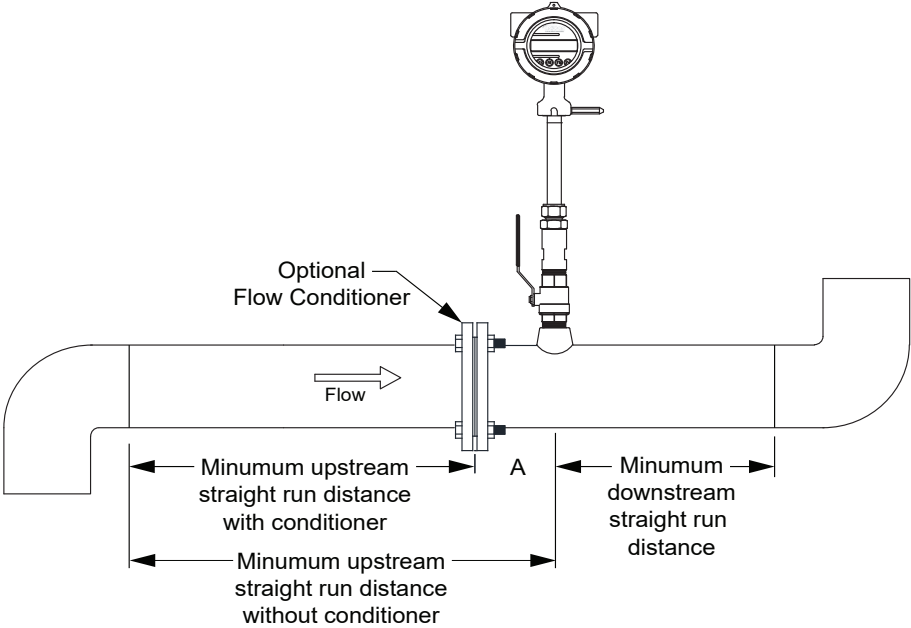
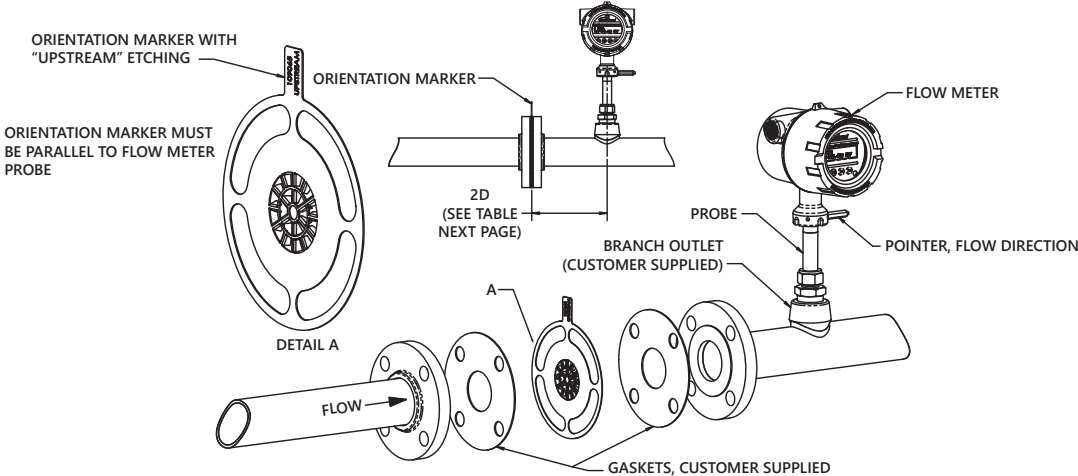

Fig. 2.3: Placement of Optional Flow Conditioners in Pipe

ONICON flow conditioners are designed to be installed between two flanges (provided by installer) that are located 2 pipe diameters upstream of the flow sensor. The use of flow conditioners significantly reduces the upstream straight pipe length requirement for flow sensor. The size of the flow conditioner must match the pipe size.

Straight Run Requirements for Upstream Obstructions - Insertion

Upstream Obstruction	Straight run required upstream of meter location without flow conditioner	Straight run required upstream of flow conditioner mounting flange	Straight run required downstream of meter location
Single bend preceded by ≥ 9 diameters of straight pipe	15 Diameters	3 Diameters	5 Diameters
Pipe size reduction in straight pipe run	15 Diameters	3 Diameters	5 Diameters
Multiple bends in plane with < 9 diameters of straight pipe between them	20 Diameters	9 Diameters	5 Diameters
Pipe size expansion in straight run	30 Diameters	10 Diameters	5 Diameters
Tees	30 Diameters	10 Diameters	5 Diameters
Multiple bends out of pipe	40 Diameters	10 Diameters	5 Diameters
Modulating or regulating valve	40 Diameters	10 Diameters	5 Diameters



IMPORTANT NOTICE

Always use the maximum available straight run. When more than the minimum required straight run is available place the meter such that the excess straight run is upstream of the meter location.

2.4 SENSOR ORIENTATION DIRECTION OF FLOW

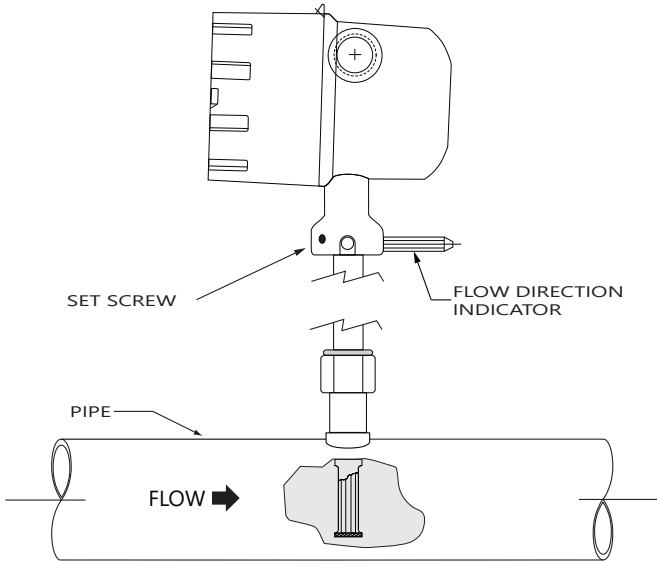

Install the meter with the flow direction arrow on the enclosure pointing in the direction of flow in the pipe.

Fig. 2.4: Orientation of Flow Meter

2.5 SENSOR ELEMENT ALIGNMENT

Sensor Elements

Every F-5400 flow meter is equipped with equal length sensor elements. To be sure that the flow meter elements are lined up correctly in the process stream, please refer to "Fig 2.4: Orientation of Flow Meter" on page 13 and be sure that the Flow Direction Indicator is pointing in the direction of flow in the pipe.

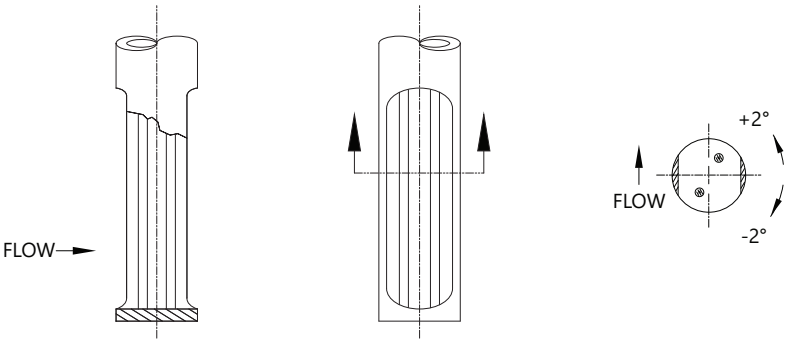

Note: Rotational misalignment should not exceed $\pm 5^\circ$.

Fig. 2.5: Sensor Elements

Installing the Sensor

There are two different versions of the insertion style F-5400. The standard version and the high pressure version are shown below.

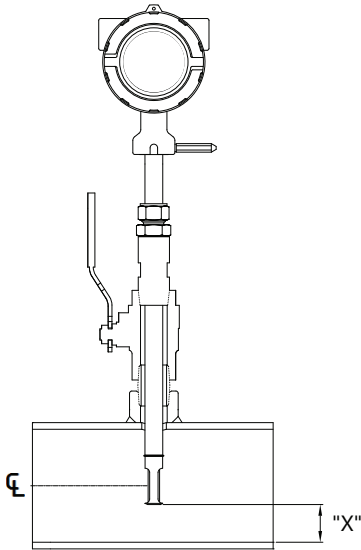

The standard version of the F-5400 is hand insertable into pipes with operating pressures up to 60 psig.

Fig. 2.6a: Standard F-5400

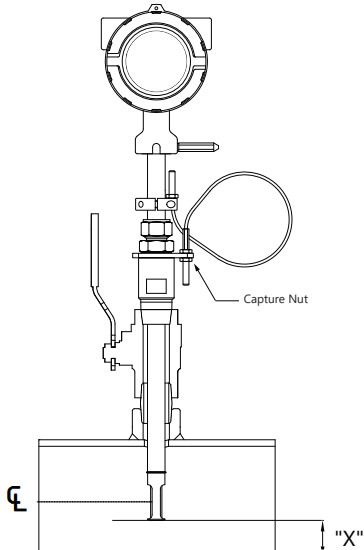

The high pressure version of the F-5400 is hand insertable up to 100 psig. For applications above 100 psig, it is necessary to isolate flow and relieve pressure before attempting to install or remove the meter. The maximum operating pressure for this version of the meter is 150 psig.

Fig. 2.6b: High Pressure F-5400

Installation Procedure

The installation depth of the sensor in the pipe is dependent on the pipe size. To get the most accurate reading, proper placement of the sensor window within the pipe is necessary. Use the following procedure to determine the proper depth setting for your meter. The procedure is valid for nominal pipe sizes 1.5" through 8". The maximum allowable height of the installation hardware (branch outlet, close nipple & ball valve) is 6" as measured from the outside wall of the pipe to the top of the valve. Procedure:

1. Locate the pipe inside diameter (ID) listed on the calibration information label on the side of the flow meter enclosure. This information is also available on the calibration certificate.
2. Confirm that this ID corresponds to the nominal diameter of the pipe where the meter is installed.
 - a. To determine the nominal pipe size, measure the circumference of the pipe without the insulation and divide this value by pi (3.14). This will give you the outside diameter (OD).
 - b. Use the table below to locate the nominal pipe size and ID based on the OD.
 - c. The table provides dimensions for common schedule 40 and schedule 80 pipes.
 - d. Contact ONICON for assistance if your pipe dimensions are not shown.
3. Once the ID is confirmed, prepare to insert the flow sensor by ensuring the compression fitting is loose.
4. Thread the process adapter fitting on to the ball valve and tighten. Use the appropriate thread sealant, as required, to ensure a leak free connection.
5. Open the ball valve and carefully insert the flow sensor until the end of the stem just contacts the opposite wall of the pipe.
6. Mark the position of the stem where it exits the top of the compression fitting.
7. Withdraw the stem "X" distance as measured from the top of the compression fitting. At the same time, position the electronics enclosure parallel to the pipe in the correct orientation relative to the flow direction as shown in "Fig. 2.4 Orientation of Flow Meter" on page 13. This will position the sensor with its axis in line with the flow and in the correct direction.
8. Read the instructions on the next page before tightening the compression fitting.
 -- FOR METERS WITH THE HIGH PRESSURE SAFETY CABLE --
9. Once the compression fitting is tight, attach the safety cable using the capture nut provided.
10. If necessary, rotate the top clamp to re-align the cable with the bottom clamp. When rotating the clamp, make sure that it remains at the top of the stem pressed firmly against the spacer. (see appendices for details)

Nominal Dia.	OD	ID		X		Min. Stem Length*
		Sch. 40	Sch. 80	Sch. 40	Sch. 80	
1½"	1.900"	1.610"	1.500"	Always use 0.1"		15"
2"	2.375"	2.067"	1.939"	0.304"	0.240"	15"
2½"	2.875"	2.469"	2.323"	0.505"	0.432"	15"
3"	3.500"	3.068"	2.900"	0.804"	0.720"	15"
4"	4.500"	4.026"	3.826"	1.283"	1.183"	15"
6"	6.625"	6.065"	5.761"	2.303"	2.151"	18"
8"	8.625"	7.981"	7.625"	3.261"	3.083"	18"

*refer to model number coding to determine the stem length of your meter.

Compression Fittings

While holding the fitting body steady, finger tighten the nut. Then, tighten the nut with wrenches an additional one and one-quarter (1¼) turn. If beginning at 6 o'clock, the wrench would make one full turn back to 6 o'clock and rest at the 9 o'clock position for proper compression. See Figure 2.7 below.



CAUTION

Tightening the compression fitting will crimp the fitting to the stem of the flow meter and lock the depth setting into place. Don't tighten the compression fitting until you've completed all steps in the installation section of this manual.

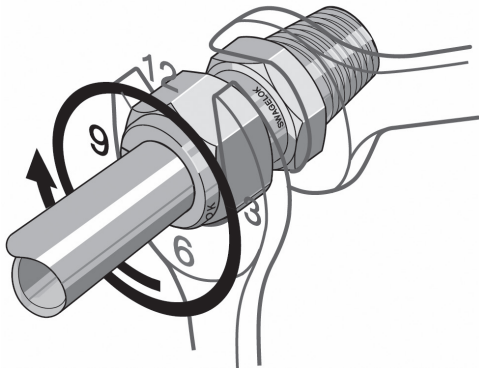

Fig. 2.7: Proper Tightening of the Compression Fitting Nut

Removal of the Meter

Follow these instructions for safe removal of the meter from the pipe.



WARNING

SYSTEM MAY BE UNDER HIGH PRESSURE
Do not attempt to remove meters with the standard process adapter fitting from a pipe pressurized above 60 psig without first relieving pressure in the pipe.
Do not attempt to remove any meter with the high pressure process adapter fitting and cable assembly from a pipe pressurized above 100 psig without first relieving pressure in the pipe.



WARNING

When removing the flow meter, be sure to hold the electronics enclosure firmly by hand before unscrewing the compression fitting nut. Failure to do this will allow the pressure in the pipe to suddenly and rapidly force the meter from the pipe potentially causing serious injury. The meter could also be damaged resulting in a loss of gas from the pipe. The force required to hold the meter will be 0.44 times the pipe pressure. If you are unsure of your ability to hold the meter for any reason, do not loosen the compression fitting nut.

Procedure:

1. Slowly unscrew the compression fitting nut while maintaining a firm grip on the enclosure to counteract the effect of pressure in the pipe.
2. Once the nut is fully disengaged from the threads, the meter will be free to move. Carefully withdraw the flow meter stem from the pipe until the sensor head is fully inside the process adapter fitting.
3. After the meter is completely withdrawn, slowly close the valve to isolate flow.

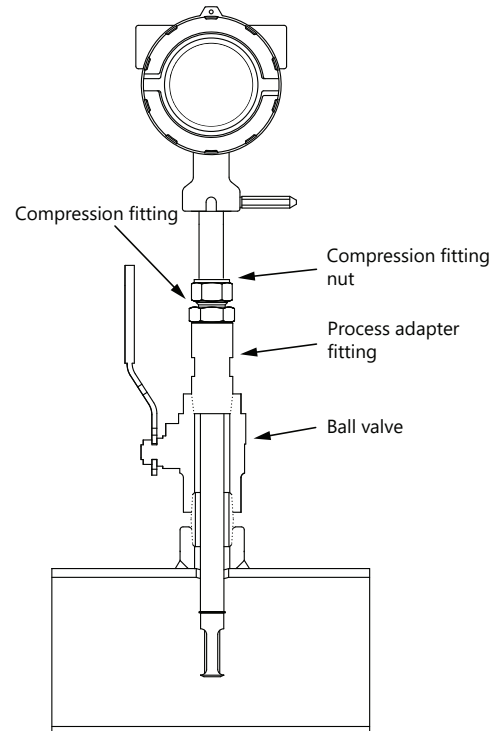

IMPORTANT NOTICE

At this point, the flow meter is isolated from the pipe, but the process adapter fitting will contain a small volume of process gas under pressure.

4. After the valve is completely closed, slowly unscrew the compression fitting from the top of the process adapter fitting leaving the adapter fitting on the ball valve.



IMPORTANT NOTICE

As the compression fitting is removed, pressure will be vented from the ball valve.

5. For meters provided with the high pressure adapter fitting, disconnect the safety cable at the bottom by removing the capture nut (refer to Figure 2.6b). Be sure to fully re-attach the nut to the cable once the meter is removed from the pipe.

Instructions for Inline Flow Meter Placement

Install the Model F-5400 Inline style flow meter so that is far enough away from bends in the pipe, obstructions, or changes in line sizes to ensure a consistent flow profile. Review the straight run requirements table on page 19.

The Model F-5400 is threaded or flanged to the customer’s pipe. Care should be taken to ensure that the diameter of the mating pipe is the same diameter as the Model F-5400 flow body or errors in flow readings can occur. The installation procedure should be a combination of the end user’s best engineering practices, in compliance with local codes, and the manufacturer’s recommendations.

The F-5400 inline meters come with 2 pieces, the flow body and the meter itself. The meters are swaged from the factory to set the ferrule with the correct corresponding insertion depth based on the application.

See “Straight Run Requirements for Upstream Obstructions - Inline” on page 19 for a detailed look at upstream and downstream pipe diameters for inline meters.

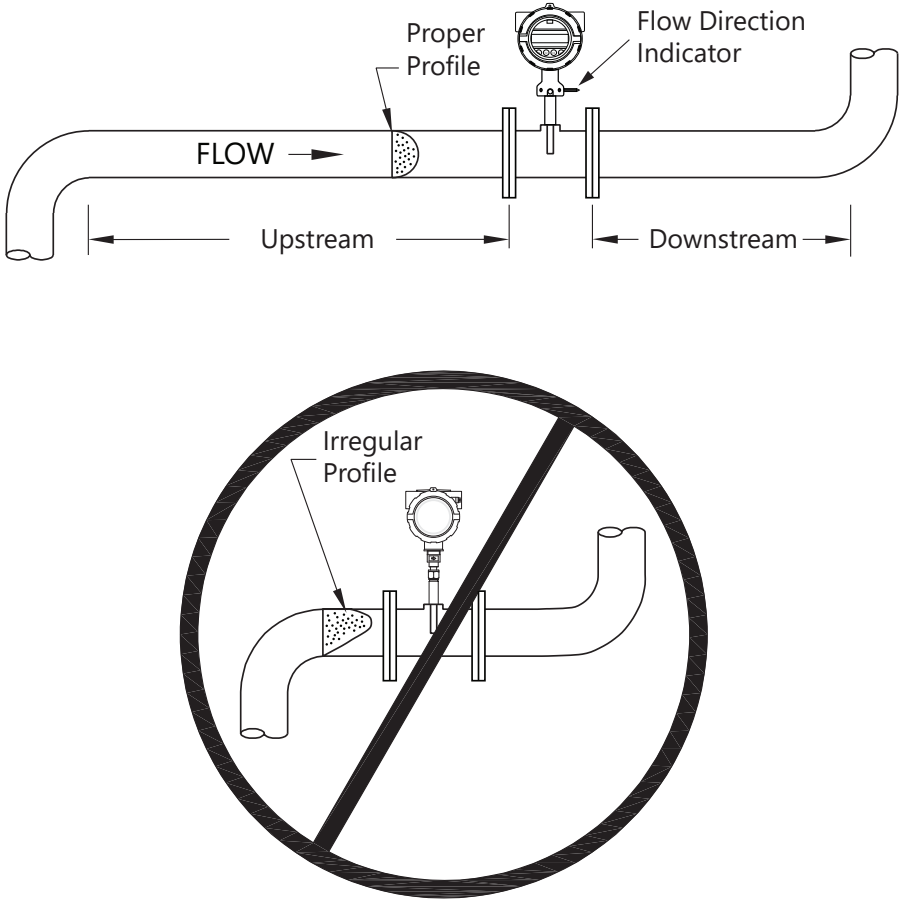

Fig. 2.8: Upstream and Downstream Pipe IDs for Inline Meters

Straight Run Requirements for Upstream Obstructions - Inline

Upstream Obstruction	Minimum straight run required upstream of flow meter process connection based on the nature of the upstream obstruction.								
	¾"	1"	1¼"	1½"	2"	2½"	3"	4"	6"
Single bend preceded by ≥9 diameters of straight pipe OR Pipe size reduction in straight pipe run	2.25"	3"	3.75"	4.5"	6"	7.5"	9"	12"	18"
Multiple bends in plane with <9 diameters of straight pipe between them OR Pipe size expansion in straight run	6.75"	9"	11.25"	13.5"	18"	22.5"	27"	36"	54"
Tees	7.5"	10"	12.5"	15"	20"	25"	30"	40"	60"
Multiple bends out of plane	7.5"	10"	12.5"	15"	20"	25"	30"	40"	60"
Modulating or regulating valve OR Diaphragm or roots type utility meters	9"	12"	15"	18"	24"	30"	36"	48"	72"
	Minimum downstream straight run required after flow meter process connection								
	2.25"	3"	3.75"	4.5"	6"	7.5"	9"	12"	18"

Flow Body Orientation Inline Type

Install the flow body so that the arrow on the enclosure is pointing in the direction of flow.

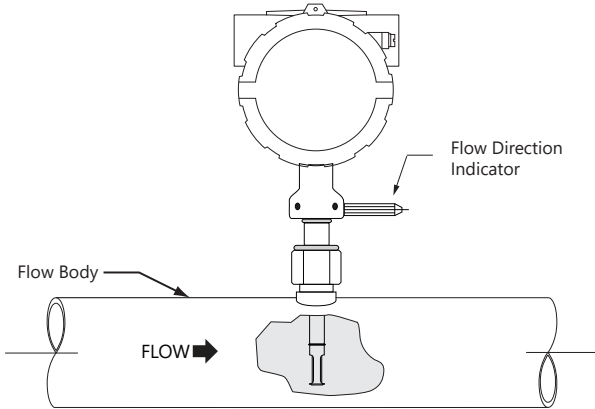

Fig. 2.9: Orientation of an Inline Meter - Flow Direction Indicator



IMPORTANT NOTICE

ONICON does not supply gaskets for this product.

SECTION 3.0: WIRING

3.1 Wiring Instructions

To wire the F-5400, unscrew and remove the enclosure cap and loosen the two captive screws on the metal shield. Rotate the shield to access the wiring terminals.

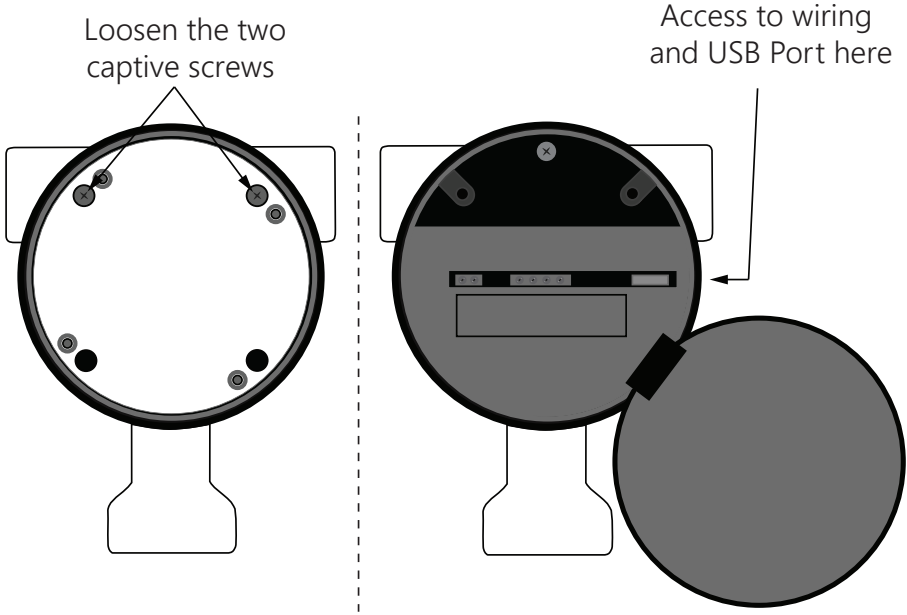

Fig. 2.10: Accessing Wiring Terminals

Connect the power and signal wires to the terminal blocks according to the label and instructions on the following pages.

Cut all wires as short as allowable for a minimum service loop. Obtain the correct length for the F-5400 wires using one of these methods:

- Trim the wires to extend 2 inches out of the enclosure after the conduit and wires are routed to the F-5400.
- Trim the wires to extend 5 inches from the end of the conduit before attaching them to the F-5400.

Wiring Precautions



WARNING

- Do not open the enclosure when energized or an explosive atmosphere is present.
- Connect earth ground to a chassis ground screw on the inside or outside of F-5400 enclosure to reduce the potential of an eletrostatic charging hazard.
- All plumbing and electrical installations of flow meters must be in compliance with local codes, the end user’s best engineering practices, and manufacturer’s recommendations.
- Do not install the F-5400 enclosure near an igniter, igniter-controller or switching equipment to eliminate the possibility of noise interference.
- Do not install an external power supply in a cabinet containing an igniter controller or switching equipment.
- This flow meter contains components that can be damaged by static electricity. You must discharge yourself by touching a grounded steel pipe or other grounded metal prior to working inside this flow meter.
- Close any unused conduit entries using suitably certified plugs.

3.2 Power Wiring

For wiring the 12 to 28VDC power, use stranded copper wire, no larger than 16-gauge. Twisted pair shielded cable is recommended. Supply connection wiring must be rated for at least 90°C.

3.3 Grounding

The enclosure must be properly grounded with a quality earth ground, 16 gauge, stranded wire is recommended. For US and Canada installation, the internal ground terminal on the enclosure must be used. Use of the external ground terminal is optional.

3.4 Signal Wiring

For signal wiring, the recommended wire gauge is 18 to 22 AWG. Always use twisted pair shielded cable.

3.5 Power Input Requirements: 12 to 28VDC Supply

External DC power supply must provide 12 to 28VDC (10 to 30VDC full input power range) at 6 Watts minimum.

(With 12 VDC power, the F-5400 can use up to 500mA. With 24 VDC power, the F-5400 can use up to 250mA)

A 20 Watt or greater power supply is recommended to ensure it can provide enough current under all temperature, ventilation, and power on conditions.

The enclosure must be properly grounded with a quality earth ground. Sixteen (16) gauge, stranded wire, is recommended for power and earth ground.

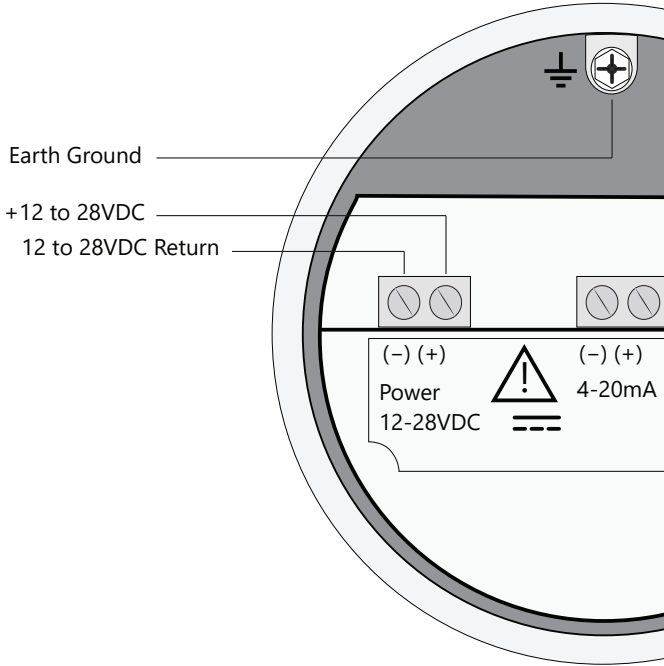

Fig. 3.1: Connections for 12 to 28VDC Supply



CAUTION

Supply connection wiring must be rated for at least 90°C.

3.6 4-20mA Output Wiring: Customer-Supplied Power Source

Bring the 4-20mA wiring in through either conduit hub. Connect 4-20mA wiring as shown in the diagram below.

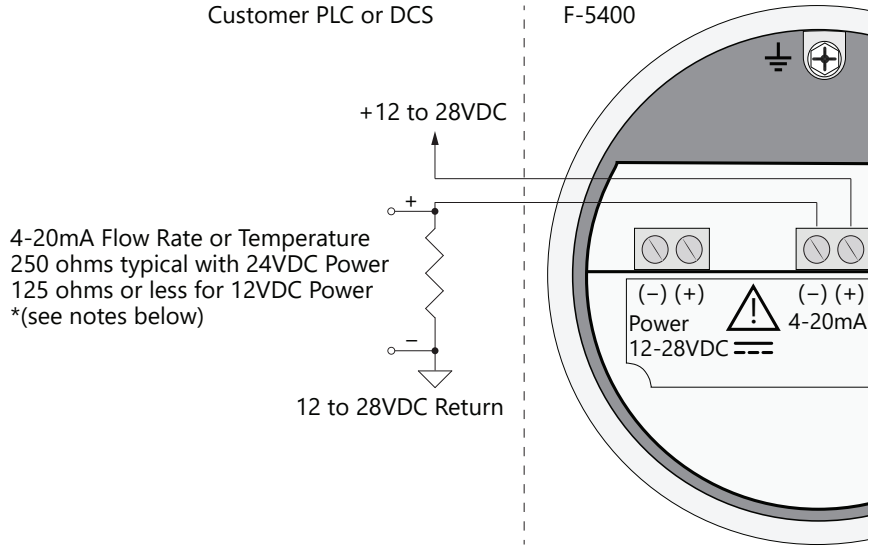

Fig. 3.2: 4-20mA Output Wiring for Customer-Supplied Power Source



IMPORTANT NOTICE

- When using a 12 volt power supply, the load resistor on the 4-20mA output must be 125 ohms or less to operate properly.
- When using 24 volt power, the load resistor is typically 250 ohms. A 250 ohm resistor in the 4-20mA circuit will result in a 1 to 5 volt signal to the PLC or DCS.
- When using a 24 volt power supply, the load resistor on the 4-20mA output must be 600 ohms or less.
- Some PLC and DCS equipment have built in load resistors, please refer to the technical manuals of such equipment.

3.7 4-20mA Output Wiring: Loop Power Provided by F-5400

Bring the 4-20mA wiring in through either conduit hub. Connect the 4-20mA as shown in the diagram below.

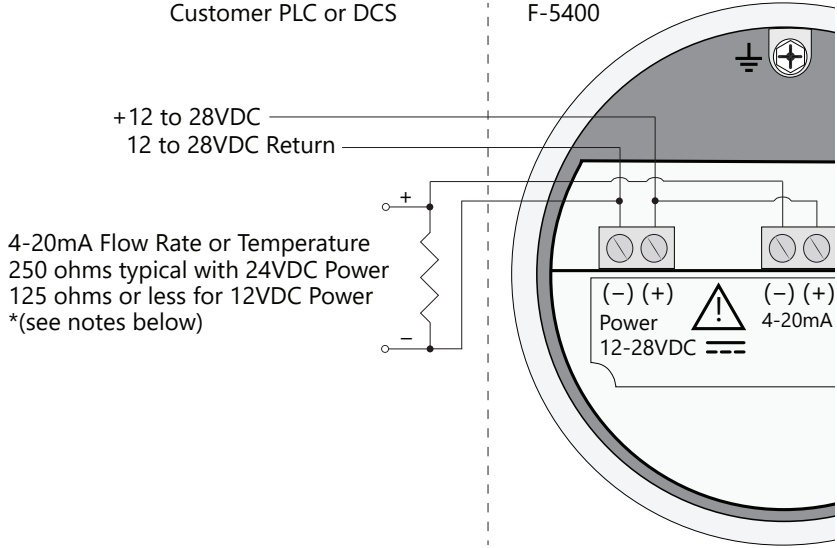

Fig. 3.3: 4-20mA Output Wiring for Loop Power Provided by F-5400



IMPORTANT NOTICE

- When using a 12 volt power supply, the load resistor on the 4-20mA output must be 125 ohms or less to operate properly.
- When using 24 volt power, the load resistor is typically 250 ohms. A 250 ohm resistor in the 4-20mA circuit will result in a 1 to 5 volt signal to the PLC or DCS.
- When using a 24 volt power supply, the load resistor on the 4-20mA output must be 600 ohms or less.
- Some PLC and DCS equipment have built in load resistors, please refer to the technical manuals of such equipment.

3.8 Pulse/Alarm Output Wiring: Customer Supplied Power Source (Recommended)

Bring pulse/alarm wiring in through either conduit hub. Connect as shown in the diagram below. The pulse/alarm output is an open collector circuit capable of sinking a maximum of 20mA of current. Pulse or alarm selection is programmed using F-5000 View. Only one option, pulse or alarm, can be active at a time. The pulse output is normally low (open collector output closed) and pulses high +12 to 24VDC (open collector output open) for 500 milliseconds when the total flow is measured. The maximum frequency setting of the pulse output is 1 Hz.

When the output is configured for Alarm, the open collector output will be open when there is no alarm and closed when an alarm is present.

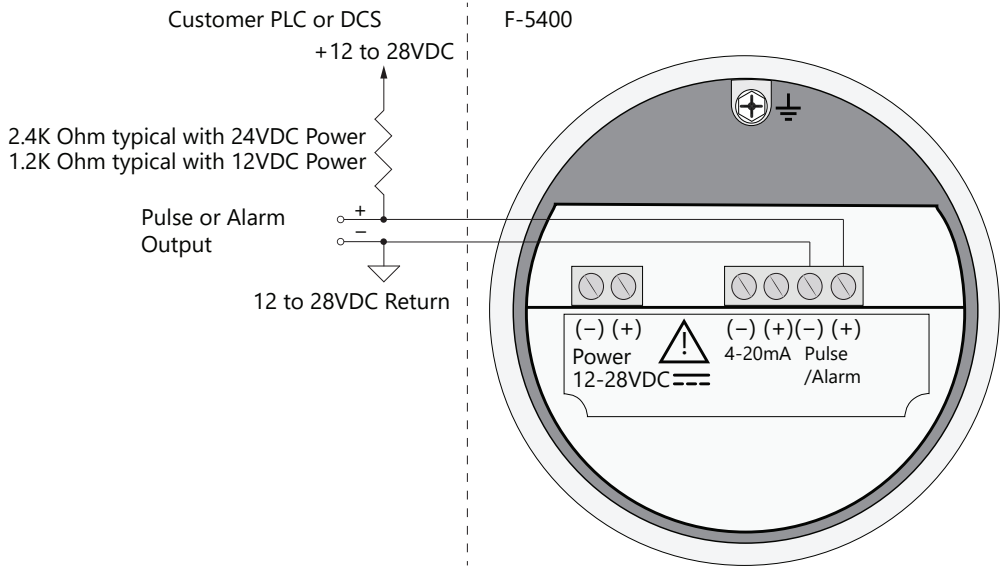

Fig. 3.4: Pulse/Alarm Output Isolated (Recommended)



IMPORTANT NOTICE

- The F-5400 Pulse/Alarm output is typically used to drive digital circuitry or solid-state relays. The output of a solid state relay may, in turn, operate loads such as electromechanical relays or alarm indicators.
- The maximum load current of the Pulse/Alarm output is 20mA. Choose a load resistance that provides approximately 10mA with the power supply operating voltage.
- When the output is configured for Alarm and an alarm is not active, the output will be closed (0 volts output). When an alarm is active, the output will be open (12 to 28 volts output).

3.9 Pulse/Alarm Output Wiring: Power Provided by F-5400

Bring pulse/alarm wiring in through either conduit hub. Connect as shown in the diagram below. The pulse/alarm output is an open collector circuit capable of sinking a maximum of 20mA of current. Pulse or alarm selection is programmed using F-5000 View. Only one option, pulse or alarm, can be active at a time.

When the output is configured for Alarm, the open collector output will be open when there is no alarm and closed when an alarm is present.

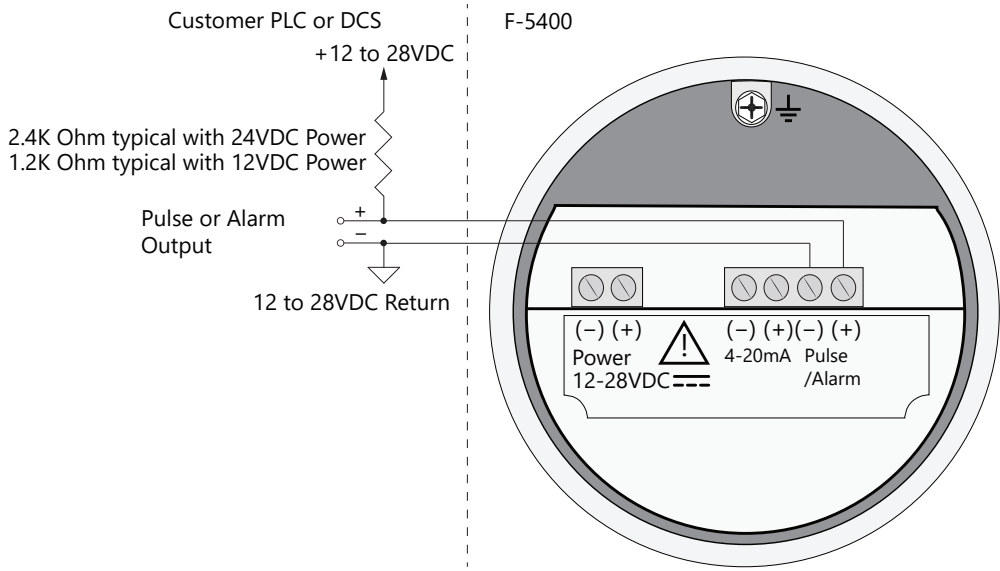

Fig. 3.5: Pulse/Alarm Output Power Provided by F-5400



IMPORTANT NOTICE

- The F-5400 Pulse/Alarm output is typically used to drive digital circuitry or solid-state relays. The output of a solid state relay may, in turn, operate loads such as electromechanical relays or alarm indicators.
- The maximum load current of the Pulse/Alarm output is 20mA. Choose a load resistance that provides approximately 10mA with the power supply operating voltage.
- When the output is configured for Alarm and an alarm is not active, the output will be closed (0 volts output). When an alarm is active, the output will be open (12 to 28 volts output).

SECTION 4.0: OPERATION: START-UP

4.1 Start Up Sequence

The F-5400 automatically enters the Run/Measure mode, measures gas flow and transmits measurement data after power up.

4.2 Programming and Configuring Flow Meter and Flow Meter Settings

The F-5400 is a field configurable flow meter. To access the flow meter settings, open the cover of the enclosure and use the mini USB port to connect the flow meter to a PC or laptop. Download and run the F-5000 View software while connected to the F-5400 USB port.

Please refer to the F-5000 View Manual for specific instructions on the function and usage of the software to configure your meter.

The latest version of the F-5000 View software is available for download at <https://www.onicon.com/products/f-5400-series-thermal-mass-flow-meter>

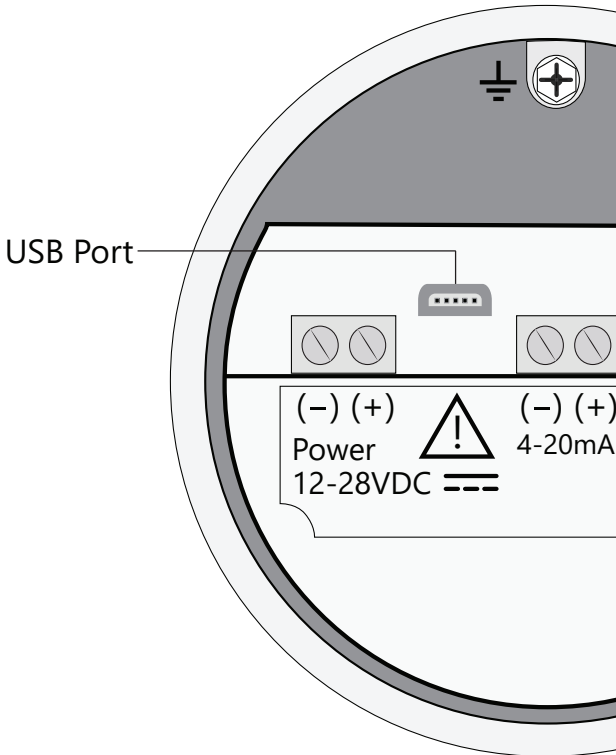

Fig. 4.1: Locating the Mini USB Port



WARNING
Before attempting any maintenance, take the necessary safety precautions before removing the probe from the duct (Example: Purge lines of toxic and/or explosive gas, depressurize, etc...)



WARNING
Explosion Hazard. Do not remove or replace components or fuses unless power has been disconnected when a flammable or combustible atmosphere is present.



WARNING
Explosion Hazard. Do not disconnect equipment when a flammable or combustible atmosphere is present.

4.3 Access to Electronics

Accessing electronics is not normally required for maintenance purposes. If a loose connection is suspected, open the cover of the meter to access the wiring terminations.



CAUTION
Be sure to power to meter is switched off before attempting to access electronics. If there is a problem and a loose connection is not found, please contact ONICON Customer Service for technical assistance at 727-447-6140.

4.4 Broken or Damaged Probe

If the sensor is broken or damaged, the probe and electronics must be returned to the factory. A new sensor will be installed and calibrated. Refer to "Returning Your Meter" on page 39.

4.5 Flow Calibration

To ensure continued high accuracy of your Model F-5400 Flow Meter, ONICON provides a full NIST traceable calibration.

4.6 Fuse Replacement



WARNING
Turn input power OFF before removing or installing a fuse. Use only recommended fuse replacements.

Verify the fuse is defective by measuring it with an Ohm Meter (Two replacement fuses are provided with each unit). Replacement fuse is Littelfuse part number 0454.750OMR.

To replace the fuse: The fuse F1 is located near the power terminal block and can be removed by using tweezers or needle-nose pliers.

4.7 Sensor Cleaning

The sensor is insensitive to small amounts of residue, but continued use in dirty environments will necessitate periodic cleaning. To inspect the sensor, remove power from electronics and remove the unit from the pipe or duct, exposing the sensor elements. If they are visibly dirty, clean them with water or alcohol (ethanol) using an appropriate brush until they appear clean again. Even though the sensor elements are rugged, avoid touching them with any solid object and use a light touch while cleaning them.

SECTION 5.0: TROUBLESHOOTING**CAUTION**

The electronics and sensor supplied by ONICON are calibrated as a single precision mass flow meter. Interchanging sensors will decrease the accuracy of the flow meter. If you experience any problem with your Model F-5400 flow meter, call ONICON Customer Service Department, Technical Assistance at 727-447-6140.

5.1 LED Indicators

The LED indicator near the terminal blocks of the F-5400 electronics board show the status of the F-5400. The Heartbeat LED blinks fast when the F-5400 is powered up, and blinks about once a second when the F-5400 operates normally.

Problem	Possible Cause(s)	Action(s)
Flow measurement seems low	<ol style="list-style-type: none"> 1. Probe not oriented properly 2. Sensor dirty 	<ol style="list-style-type: none"> 1. Orient probe per Insertion Installation section (p. 10) 2. Clean sensor (p. 27)
Unit will not power-up	<ol style="list-style-type: none"> 1. No power input 2. Bad fuse 3. Bad power supply 	<ol style="list-style-type: none"> 1. Check fuse (F1) located next to TS1 on main board. 2. Check for correct power supply voltage at TS1 on main board. <p>If fuse is OK and unit still won't power up, call ONICON for additional assistance</p>
Meter resets	<ol style="list-style-type: none"> 1. Intermittent power 2. Electromagnetic interference (EMI) 	<ol style="list-style-type: none"> 1. Measure the power input voltage. 2. Check Power input and output cables grounding and routing.
Flow measurement is erratic or fluctuating	<ol style="list-style-type: none"> 1. Very turbulent flow 2. Sensor dirty 3. Sensor broken 4. Probe not mounted securely 5. Malfunction in flow meter 6. Meter installed incorrectly 	

5.2 Installation Problems

The following is a summary listing of problems that may be encountered with the installation of the F-5400 Thermal Mass Flow Meter.

1. Improper wiring connections for power and/or 4-20mA output signal.

A separate power source is recommended for the F-5400 main board and the 4-20mA output signals. Two wires supply 24VDC power to the main board. Two wires are used for the 4-20mA output signals. Refer to wiring section (p. 20) for further guidance.

2. Inadequate power source.

The F-5400 requires 12 to 28VDC at up to 6 Watts to operate. A 20 Watt power supply is recommended for powering the F-5400 to ensure it operates properly under all conditions. If the the voltage supplied at the input terminals of the F-5400 is not within the range, a variety of problems will occur.

3. Flow measurement seems inaccurate.

- Check to ensure that the flow meter is installed so that the flow direction indicator is pointed in the direction of flow. Refer to Figure 2.4 (p. 13). If not, change orientation of meter.
- Check that the insertion depth of the sensor/probe is correct. The end of the probe should be adjusted as per Figure 2.6a (p. 14).
- Ensure that the proper upstream and downstream pipe requirements have been met. Use "Fig. 2.1: Upstream and Downstream Pipe IDs for Insertion Meters" on page 10 and "Straight Run Requirements for Upstream Obstructions - Insertion" on page 13 to determine the required lengths. If complex flow disturbances are upstream of the sensor, extension of the straight pipe may be required to ensure accurate flow measurement. Contact ONICON for assistance.
- Ensure that pipe inside diameter in the meter matches data on the ONICON Calibration Certificate. The pipe inside diameter is programmed into the flow meter using the F-5000 software.

4. Erratic flow reading (especially a flow reading spiking high)

This may be a symptom of moisture in the flow steam. ONICON flow meters are designed to work in relatively dry gas applications only. Contact ONICON to discuss resolutions to this problem.

5. Flow meter is not responding to flow.

Check to ensure adequate power is supplied to the flow meter. If things appear to be correct, perform this functional test before calling ONICON. Carefully remove the probe and sensor from the pipe. Blow on the sensor to see if a response occurs. If nothing happens, take a damp rag or sponge and place it in contact with the sensor. A reading should occur. Contact ONICON Customer Service with this information.

6. 4-20mA signal reading above zero flow when no flow is occurring in the pipe.

If the reading is less than 5% of full scale, it is likely this is a normal condition caused by convection flow created by the heated sensor. It does not mean that the zero of the instrument is improperly set. The ONICON sensor is extremely sensitive to gas flow and can even read the small flow caused by convection. If this is an unacceptable condition, please contact ONICON Customer Service for alternatives.

5.3 Alarm Codes

To view alarms, use the F-5000 View software and use the following table to adjust settings accordingly.

Alarm Code	Reason	Action
13	Flow rate above high limits	Refer to the F-5000 View Manual and check Alarm settings to verify limit is within range. Check ALM = HiFloAlm under PRM.
14	Flow rate below low limits	Refer to the F-5000 View Manual and check Alarm settings to verify limit is within range. Check ALM = LoFloAlm under PRM.
15	Temperature above high limits	Refer to the F-5000 View Manual and check Alarm settings to verify limit is within range. Check ALM = HiTempAlm under PRM.
16	Temperature below low limits	Refer to the F-5000 View Manual and check Alarm settings to verify limit is within range. Check ALM = LoTempAlm.
25	Simulation mode	Meter is in Simulation Mode. Refer to the F-5000 View Manual. Use the SIM Section under Diagnostics to return to normal operation.
26	Pulse/alarm output over range	Refer to the F-5000 View Manual. Verify the Pulse/alarm Output settings are within limits.
32	4-20mA is out of range	Refer to the F-5000 View Manual. Use the Set I/O section to verify range limits.
36	Database CRC Error	Refer to the F-5000 View Manual. Verify the programmed values are verified and corrected before clearing the error. Contact ONICON Service Department for possible causes.
37	Total Alarm Error	Refer to the F-5000 View Manual to Reset Total.

APPENDIX A - SPECIFICATIONS

Performance Specs

Flow Accuracy:

Natural Gas and Propane: 1% R 500 - 7000 SFPM
 Natural Gas and Propane: 2% R 100 - 500 SFPM
 Air: ±1% of reading ±0.5% of full scale
 Accuracy specification applies to customer’s selected flow range
 Maximum range: 15 to 35,000 SFPM (0.07 to 71 NMPS)
 Minimum range: 15 to 1,000 SFPM (0.07 to 4.7 NMPS)

Flow Response Time: 1 second (one time constant)

Temperature Accuracy: ±1°F (±0.6°C)

Calibration: Factory Calibration to NIST traceable standards

Operating Specs

Units of Measurement (field selectable):

SCFM, SCFM, NM3/H, NM3/M, KG/H, KG/M, KG/S, LB/H, LB/M, LB/S, NLPH, NLPM, MMSCFD, LB/D, SLPM, NLPS, MSCFD, SM3/H, MT/H, NM3/D, MMSCFM, SCFD, MCFD, SM3/M, SM3/D

Flow Velocity Range:

15 to 35,000 SFPM (0.07 to 178 NMPS)
 Turndown: up to 1000:1; 100:1 typical

Flow Ranges		
Pipe Diameter	SCFM	NM³/hr
1.5" (40mm)	0-210	0-330
2" (50mm)	0-350	0-550
3" (80mm)	0-770	0-1,210
4" (100mm)	0-1,330	0-2,100
6" (150mm)	0-3,000	0-4,730
8" (200mm)	0-5,210	0-8,220
12" (300mm)	0-11,700	0-18,450

Note: To determine if the F-5400 will operate accurately in other pipe sizes, divide the maximum flow rate by the pipe area. The application is acceptable if the resulting velocity is within the velocity range above.

Operating Specs (continued)**Relative Humidity:** Non-condensing

Note: Condensing liquids contacting the sensor can cause erratic flow indication.

Gas Pressure (maximum):

Standard Process Adapter Fitting: 60 psig (4.1 barg)

High Pressure Process Adapter Fitting: 150 psig (10.3 barg)

Inline:

Flanged, ANSI 150: 230 psig at 100°F (16 barg)

NPT: 300 psig (20.7 barg)

Temperature Accuracy:

DDC-Sensor: -40 to 250°F (-40 to 121°C)

Enclosure: -40 to 158°F (-40 to 70°C)

Input Power: 12 to 28VDC, 6 watts minimum

Full Input Power Range: 10 to 30VDC

A 20 Watt or greater power supply is recommended to power the F-5400.

Outputs:

Channel 1:

Standard isolated 4-20mA output configured to indicate either flow or temperature; fault indication per NAMUR NE43.

The 4-20mA load resistance must be 125 ohms or less when operating on 12 volt power and 600 ohms or less on 24 volt power.

Channel 2:

Pulse Output: Isolated open collector output rated for 5 to 24VDC, 20mA maximum load.

The output can be configured as a 500ms scaled pulse for totalization or as an alarm indication.

USB Communication:

Isolated mini USB 2.0 for interfacing with a laptop or computer is standard.

F-5000 View: A free PC-based software tool that provides complete configuration, remote process monitoring, and data logging functions through USB communication.

4-20mA and Pulse Verification:

Simulation mode used to align 4-20mA output and pulse output with the input to customer's PLC/DCS.

Physical Specs

Sensor material: 316 stainless steel

Enclosure: Aluminum

Flow Meter Installation for Insertion Meters:

ONICON-supplied process adapter fitting connects to ONICON or customer-supplied 1" ball valve, nipple, and branch outlet assembly.

Agency Approvals

CE Mark

EMC Directive; 2014/30/EU

Electrical Equipment for Measurement, Control and Lab Use: EN61326-1:2013

FM (USA) and FMc (Canada): Approved

Class I, Division 1, Groups B,C,D;

Class II, Division 1, Groups E,F,G;

Class III, Division 1; T4, Ta = -40°C to 70°C;

Class 1, Zone 1, AEx/Ex db IIB + H2 T4; Gb Ta = -40°C to 70°C;

Type 4X, IP66/67

APPENDIX B - DIMENSIONS

Local with Process Adapter Fitting

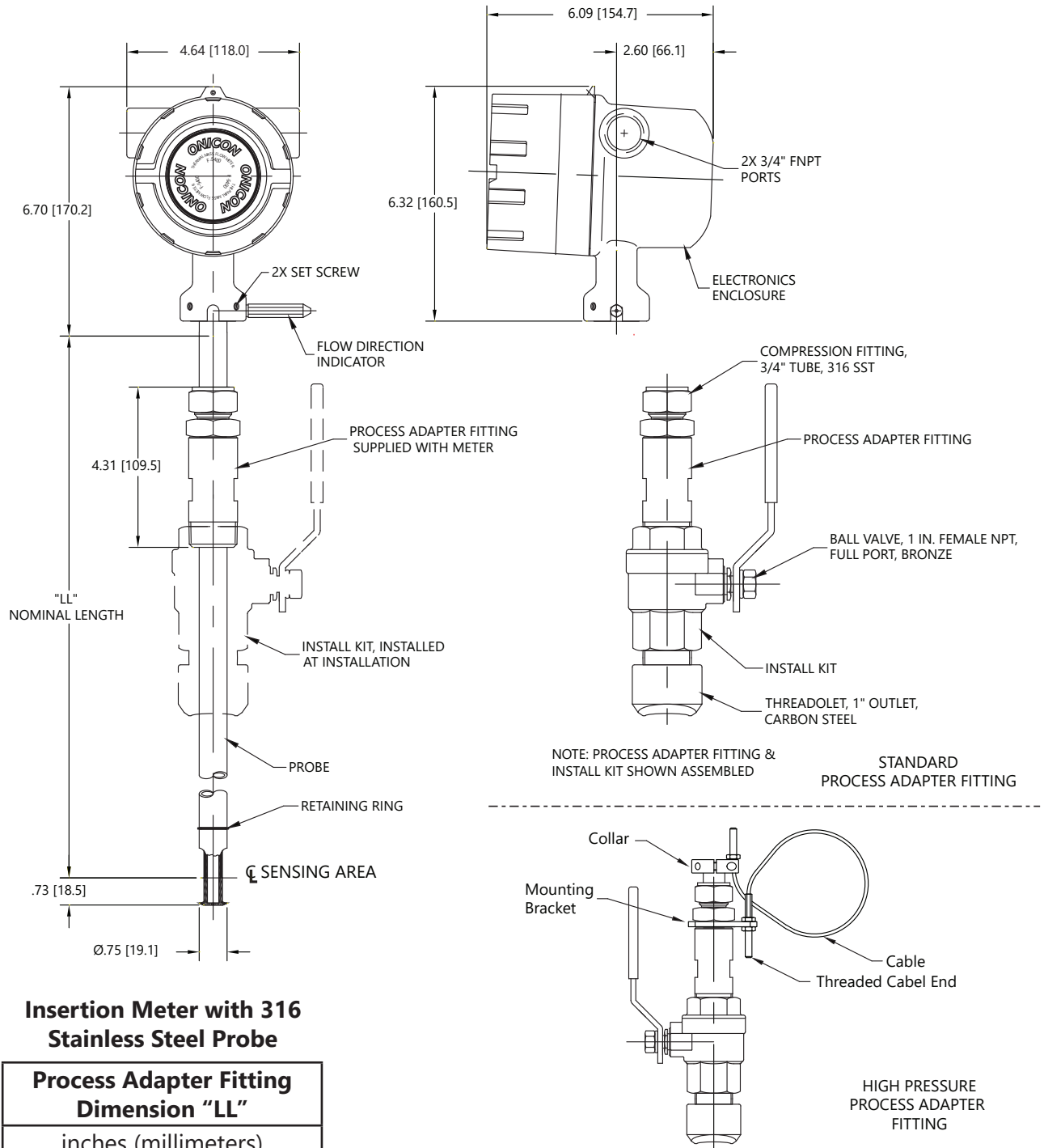

Insertion Meter with 316 Stainless Steel Probe

Process Adapter Fitting Dimension "LL"
inches (millimeters)
15.0" (381 mm)
18.0" (457 mm)

Fig. B.1: Insertion Meter with Process Adapter Fitting Dimensions Measurement shown in inches (millimeters)

Local Inline NPT Meter

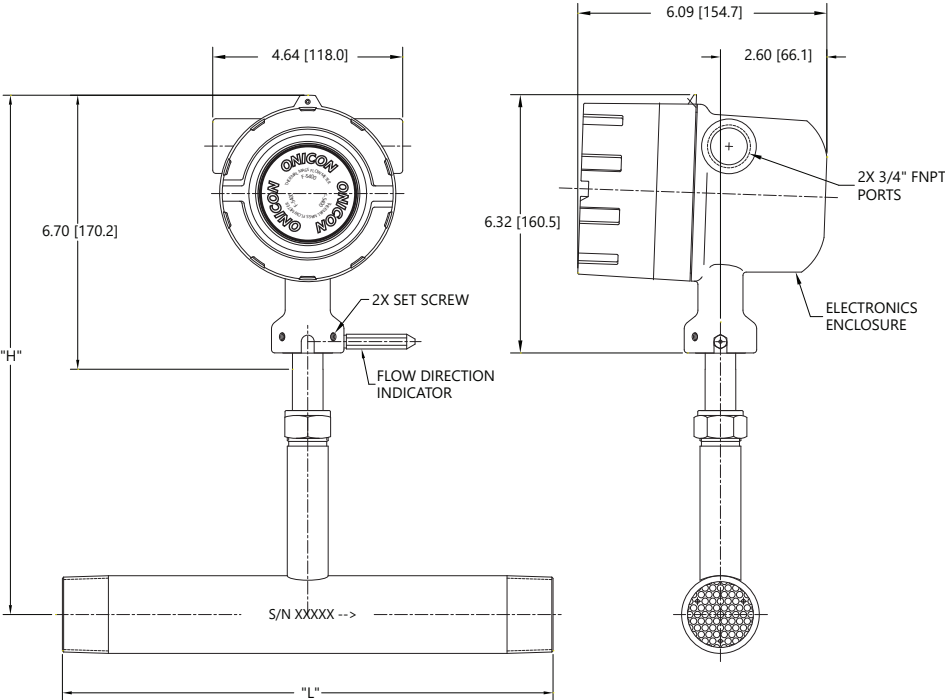

Fig. B.2: Inline Meter with 316 Stainless Steel Flow Body and NPT End Connections Dimensions

Inline Meter with 316 Stainless Steel Flow Body and NPT End Connections

Body Size	Dimesion "L"	Dimension "H"
inches	inches	inches (millimeters)
0.75"	12"	10.70" (272mm)
1.00"	12"	10.70" (272mm)
1.25"	12"	10.70" (272mm)
1.50"	12"	12.70" (323mm)
2.00"	12"	12.70" (323mm)
2.50"	18"	12.70" (323mm)
3.00"	18"	12.70" (323mm)

Local Inline Flange Meter

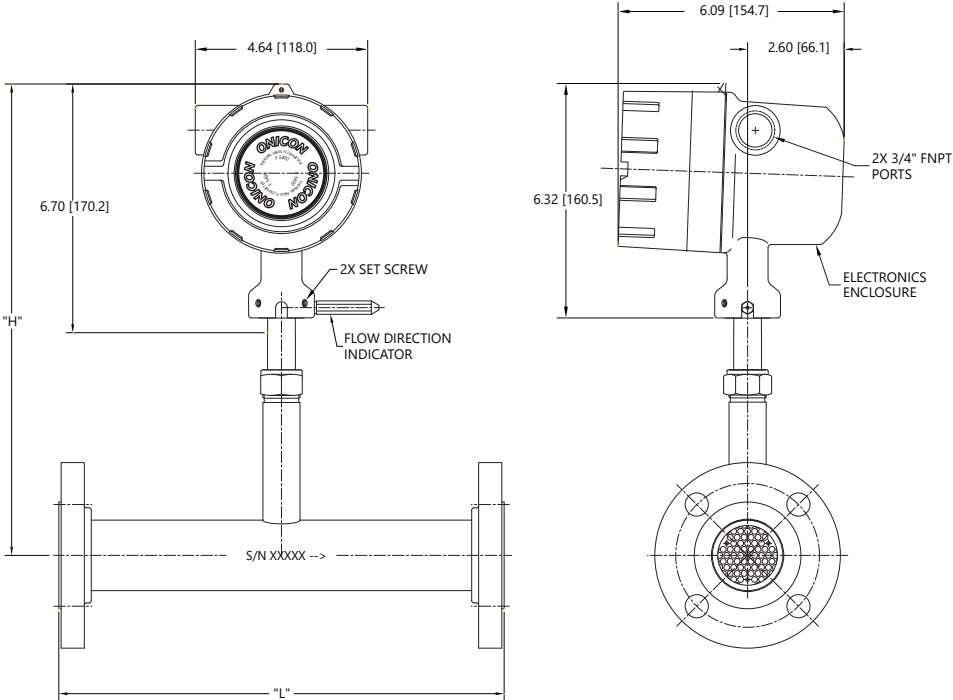

Fig. B.3: Inline Meter with 316 Stainless Steel Flow Body and 150# RF Flange End Connections Dimensions

Inline Meter with 316 Stainless Steel Flow Body and 150# RF Flange End Connections

Body Size	Dimension "L"	Dimension "H"
inches	inches	inches (millimeters)
0.75"	12"	10.70" (272mm)
1.00"	12"	10.70" (272mm)
1.25"	12"	10.70" (272mm)
1.50"	12"	12.70" (323mm)
2.00"	12"	12.70" (323mm)
2.50"	18"	12.70" (323mm)
3.00"	18"	12.70" (323mm)
4.00"	18"	12.70" (323mm)
6.00"	24"	12.70" (323mm)

APPENDIX C - WARRANTY

- a. ONICON warrants that the products furnished under this Agreement will be free from defects in material and workmanship for a period of two years from the date of shipment. The customer shall provide notice of any defect to ONICON, within one week after the Customer's discovery of such defect. The sole obligation and liability of ONICON, under this warranty shall be repair or replace, at its option, without cost to the Customer, the defective product or part.
- b. Upon request by ONICON, the product or part claimed to be defective shall immediately be returned at the Customer's expense to ONICON. Replaced or repaired products or parts will be shipped to the Customer at the expense of ONICON. ONICON shall have the right of final determination as to the existence and cause of defect.
- c. There shall be no warranty or liability for any products or parts that have been subject to misuse, accident, negligence, failure of electric power or modifications by the Customer without the written approval of ONICON. Final determination of warranty eligibility shall be made by ONICON. If a warranty claim is considered invalid for any reason, the Customer will be charged for services performed and expenses incurred by ONICON, in handling and shipping the returned unit.
- d. The liability of ONICON shall be limited to replacing or repairing, at its option, any defective parts which are returned. Labor and related expenses incurred to install replacement parts are not covered by this warranty.
- e. As to replacement parts supplied or repairs made during the original warranty period, the warranty period for the replacement or repaired part shall terminate with the termination of the warranty period of the original product or part.
- f. The use of these products is under exclusive control of the purchaser and ONICON specifically denies any responsibility for the calibration of units and/or accuracy of work performed or the safety of the system in which ONICON products is used. EXTERNAL SAFETY DEVICES MUST BE USED WITH THIS EQUIPMENT.
- g. No warranty is made with respect to custom equipment or products produced to Buyer's specifications except as specifically stated in writing by ONICON and contained in the agreement.
- h. THE FOREGOING WARRANTY CONSTITUTES THE SOLE LIABILITY OF ONICON, AND THE CUSTOMER'S SOLE REMEDY WITH RESPECT TO THE PRODUCTS AND IS IN LIEU OF ALL OTHER WARRANTIES, INCLUDING ANY WARRANTY OF MERCHANTABILITY OR FITNESS FOR A PARTICULAR PURPOSE, LIABILITIES, AND REMEDIES. EXCEPT AS THUS PROVIDED, ONICON, DISCLAIMS ALL WARRANTIES, EXPRESS OR IMPLIED, INCLUDING ANY WARRANTY OF MERCHANTABILITY OR FITNESS FOR A PARTICULAR PURPOSE.

APPENDIX D - RETURNING YOUR METER

The ONICON Customer Service Department (727-447-6140) can help you through the process of returning a meter for service.

If it becomes necessary to return a ONICON flow meter for service or recalibration, please follow these steps:

1. A Return Material Authorization (RMA) Number must be obtained from the ONICON Customer Service Department prior to returning any ONICON meter(s).
2. Please have your meter's serial number(s) available.
3. Read and complete the ONICON RMA Customer Information Form. Be sure to initial the decontamination statement as well as provide complete return shipping instructions (we cannot deliver to post office boxes).
4. The entire flow meter must be returned, including all electronics (unless specifically instructed to do otherwise). ALL serial numbers must match their corresponding meters. This is especially necessary when returning flow body models.
5. Clean and decontaminate all wetted parts before returning to ONICON.
6. Ship the meter to the following address:
ONICON
11451 Belcher Road South
Largo, FL 33773
Attn: Service Dept.
[RMA Number]

What to expect while your meter is being serviced

Depending on the type of service required when returning your ONICON meter, there are varying turnover times for servicing a meter. The average time needed to service the meter is 7-10 days (not including shipping or peak production times).

If you have already shipped your meter to ONICON for servicing and would like to check the status of your meter, please call ONICON at 727-447-6140 and ask for Service.

Rush recalibration service is available for a fee. Restrictions apply.