



ONICON SYSTEM-20 BTU METER WIRING DIAGRAM

FOR CONNECTION WITH ONICON FT-3000 SERIES
INLINE ELECTROMAGNETIC FLOW METERS



FLOW METER SIGNAL CONNECTIONS

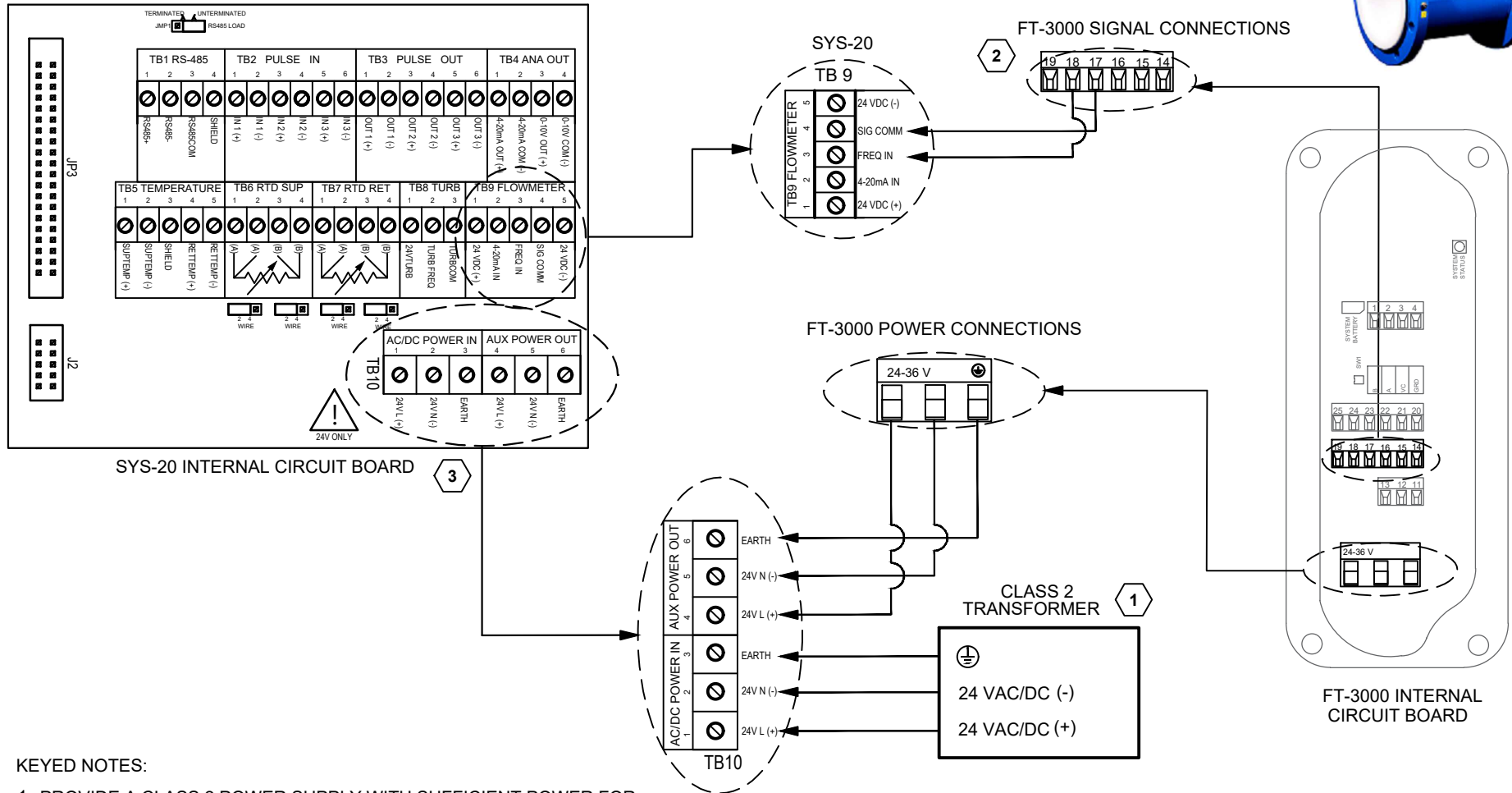

KEYED NOTES:

1. PROVIDE A CLASS 2 POWER SUPPLY WITH SUFFICIENT POWER FOR THE CONNECTED FLOW METER:
 - 24 VAC @ 1000 mA, 24 VA
 - 24 VDC @ 500 mA, 12 W
2. REFER TO FT-3000 SERIES IOM FOR ADDITIONAL WIRING INFORMATION.
3. REFER TO SYS-20 IOM FOR ADDITIONAL WIRING INFORMATION.

