

# FT-3100

## Inline Electromagnetic Flow Meter Installation and Operation Manual



## SAFETY INFORMATION

This meter was calibrated at the factory before shipment. To ensure correct use of the meter, please read this manual thoroughly.

Regarding this Manual:

- This manual should be passed on to the end user.
- Before use, read this manual thoroughly to comprehend its contents.
- The contents of this manual may be changed without prior notice.
- All rights reserved. No part of this manual may be reproduced in any form without ONICON's written permission.
- ONICON makes no warranty of any kind with regard to this material, including, but not limited to, implied warranties of merchantability and suitability for a particular purpose.
- All reasonable effort has been made to ensure the accuracy of the contents of this manual. However, if any errors are found, please inform ONICON.
- ONICON assumes no responsibilities for this product except as stated in the warranty.
- If the customer or any third party is harmed by the use of this product, ONICON assumes no responsibility for any such harm owing to any defects in the product which were not predictable, or for any indirect damages.

### SAFETY PRECAUTIONS:

The following general safety precautions must be observed during all phases of installation, operation, service, and repair of this product. Failure to comply with these precautions or with specific WARNINGS given elsewhere in this manual violates safety standards of design, manufacture, and intended use of the product. ONICON Incorporated assumes no liability for the customer's failure to comply with these requirements. If this product is used in a manner not specified in this manual, the protection provided by this product may be impaired.

The following messages are used in this manual:

#### **WARNING**

***Messages identified as "Warning" contain information regarding the personal safety of individuals involved in the installation, operation or service of this product.***

#### **CAUTION**

***Messages identified as "Caution" contain information regarding potential damage to the product or other ancillary products.***

#### **IMPORTANT NOTE**

***Messages identified as "Important Note" contain information critical to the proper operation of the product.***

- 1.0 INTRODUCTION ..... 4**
  - 1.1 Purpose of This Guide .....4
  - 1.2 Principle of Operation.....4
  - 1.3 Typical Flow Meter Applications.....4
  - 1.4 Standard Features and Specifications .....5
  - 1.5 Liner Selection .....6
  - 1.6 Model Numbering Codification.....6
  - 1.7 Additional Hardware that May Be Required .....7
    - 1.7.1 Grounding Rings.....7
    - 1.7.2 Gaskets.....8
  - 1.8 Working Environment.....8
  - 1.9 Serial Number.....8
  
- 2.0 UNPACKING 9**
  - 2.1 Documentation.....9
  - 2.2 Transmitter Configuration .....9
  - 2.3 Accessories..... 10
  
- 3.0 INSTALLATION..... 11**
  - 3.1 Site Selection..... 11
    - 3.1.1 General Guidelines ..... 11
    - 3.1.2 Flow Direction ..... 11
    - 3.1.3 Remote Mount Transmitter..... 11
    - 3.1.4 Minimum Straight Run Requirements ..... 12
  - 3.2 Mechanical Installation..... 13
    - 3.2.1 Standard Transmitter Dimensions ..... 13
    - 3.2.2 Sensor Dimensions & Weights..... 14
    - 3.2.3 Installation Drawing For Conductive Pipe..... 16
    - 3.2.4 Installation Drawing For Non-Conductive Pipe..... 18
    - 3.2.5 Installation Drawing For Threaded Connections ..... 20
    - 3.2.6 Installation Instructions ..... 21
    - 3.2.7 Torque Specifications ..... 22
    - 3.2.8 Remote Mount Transmitter..... 23
  - 3.3 Electrical Installation..... 25
    - 3.3.1 Input Power Requirements..... 25
    - 3.3.2 Power And Output Signal Wiring Instructions ..... 25
    - 3.3.3 Wiring Diagram ..... 26
    - 3.3.4 Earth Connection ..... 27
    - 3.3.5 Remote Mount Cable Wiring Instructions ..... 28
  
- 4.0 FT-3100 START-UP AND COMMISSIONING..... 29**
  - 4.1 Display and User Interface ..... 29
  - 4.2 Accessing the Programming Menus ..... 31
  - 4.3 Helpful Hints..... 32
  - 4.4 Start-Up and Commissioning ..... 32
  - 4.5 Start-Up and Commissioning Worksheet ..... 33
  - 4.6 Troubleshooting Guide..... 33

---

## SECTION 1.0 INTRODUCTION

### 1.1 PURPOSE OF THIS GUIDE

The purpose of this guide is to provide installation, commissioning procedures and basic operating instructions for the FT-3100 Inline Electromagnetic Flow Meter.

### 1.2 PRINCIPLE OF OPERATION

The operating principles of the ONICON FT-3100 Inline Electromagnetic Flow Meters are based on Faraday's Law of Electromagnetic Induction. Faraday's Law states that a voltage will be induced in a conductor (water or other conductive liquid) when the conductor passes through a magnetic field (generated by the meter), and the induced voltage will be directly proportional to the velocity of the conductor. By placing electrodes on opposite sides of the flow tube, it is possible to accurately measure the induced voltage and determine the corresponding velocity of the flowing liquid.

#### **WARNING**

***Only qualified service personnel should attempt to install or service this product. Serious injury may result from the improper installation or use of this product.***

### 1.3 TYPICAL FLOW METER APPLICATIONS

ONICON'S FT-3000 Series Inline Electromagnetic Flow Meters are suitable for volumetric flow measurement of electrically conductive fluids in a wide variety of applications.

1.4 STANDARD FEATURES AND SPECIFICATIONS

<b>FT-3100 TRANSMITTER</b>		
PERFORMANCE	ACCURACY	±0.4% of reading from 3.3 to 33 ft/sec ±0.75% of reading from 1.3 to 3.3 ft/sec ±0.0075 ft/sec at flow rates less than 1 ft/sec
	MINIMUM CONDUCTIVITY	5 µS/cm
INPUT POWER**	AVAILABLE OPTIONS	<ul style="list-style-type: none"> <li>Low Power, 24 VAC/DC, 50/60 Hz, 12 VA</li> <li>High Power, 120 - 240 VAC, 50/60 Hz, 12 VA</li> </ul>
I/O SIGNALS**	AVAILABLE OPTIONS	<ul style="list-style-type: none"> <li>Two (2) digital outputs, one (1) digital input, and one (1) analog output</li> <li>MODBUS RTU (RS485)</li> </ul>
ELECTRONICS ENCLOSURE**	IP67 (NEMA 4X) enclosure with display	
	AVAILABLE OPTIONS	<ul style="list-style-type: none"> <li>Integral mount</li> <li>Remote (wall) mount with kit, up to 164 ft in fluids with conductivity ≥200 µs/cm</li> </ul>
	DISPLAY	16-character, 8-line, 128x64 graphic LCD with back light
	AMBIENT CONDITION	Transmitter: 14°F to 140°F
PROGRAMMING	AVAILABLE OPTIONS	<ul style="list-style-type: none"> <li>Menu driven user interface via three (3) programming keys</li> <li>PC user interface via micro USB and downloadable software</li> </ul>
ELECTRICAL CONNECTIONS	INPUT POWER	Removable terminal blocks for use with 14 - 22 gauge wire
	I/O SIGNALS	Removable terminal blocks for use with 18 - 24 gauge wire
	COIL & ELECTRODES	Removable terminal blocks for use with sensor cable provided
APPROVAL	CE	2014/30/EU EMC Directive
<b>FT-3000 SERIES FLOW SENSOR</b>		
PERFORMANCE	SENSING METHOD	Electromagnetic sensing (no moving parts)
OPERATING CONDITIONS	FLUID TEMPERATURE RANGE	See Liner Selection Table on next page
	FLUID PRESSURE RANGE	See Liner Selection Table on next page
FLOW SENSOR DESIGN**	FLOW TUBE	304 SS
	ELECTRODES	Qty: Three (3), round, 316 SS
FLOW BODY**	AVAILABLE OPTIONS***	<ul style="list-style-type: none"> <li>Carbon Steel</li> <li>Polypropylene</li> <li>Stainless Steel</li> </ul>
FLOW LINER**	AVAILABLE OPTIONS***	<ul style="list-style-type: none"> <li>PTFE</li> <li>Ebonite</li> <li>Polypropylene</li> </ul>
PROCESS CONNECTIONS**	AVAILABLE OPTIONS	<ul style="list-style-type: none"> <li>Flanged connections ANSI Class 150 or ANSI Class 300</li> <li>Wafer mount</li> <li>Threaded (NPT) connections</li> </ul>
APPROVALS	NSF	61
	CE	E97/23/CE PED Directive

**NOTE:** Specifications subject to change without notice.

\*\* See model codification for additional information regarding option selections.

\*\*\* Selection based on application.

**1.5 LINER SELECTION**

Material	Line Size Flanged and Wafer	Grade	Color	Temperature Range	Pressure Range Based on Liner	Abrasion Resistance (Carbon Steel = 100)
Ebonite	8 - 48"	Food	Amber	32°F - 175°F	580 psi (1)	90 - 118
Polypropylene	1 - 6"	Food	Gray	32°F - 140°F	232 psi	122
PTFE	1 - 48"	Food	White	0°F - 266°F (3)	580 psi (1,2)	78
Notes	Description					
1	Flanged meter pressure rating is the lesser of 580 psi or the flange rating.					
2	Wafer style meters above 6" are limited to 232 psi.					
3	Remote mount electronics option required for application temperature above 212°F.					

**1.6 MODEL NUMBERING CODIFICATION**

**METER ORDERING INFORMATION**

**Meter Model Number Coding = FT-31GG-HIJKL-BCDE**

**FLOW SENSOR CONFIGURATION INFORMATION**

**GG = Meter Size (inches)**

**Flanged and Wafer Models**

01 = 1"      25 = 2½"      05 = 5"      10 = 10"  
 15 = 1½"      03 = 3"      06 = 6"      nn = Meter Size, 12 - 24"  
 02 = 2"      04 = 4"      08 = 8"

**Threaded Models**

AA = ¼"      AC = ½"      AE = 1"  
 AB = ⅜"      AD = ¾"

**H = Liner Material**

1 = PTFE  
 2 = Polypropylene  
 3 = Ebonite

**I = Process Connection**

0 = Wafer connection  
 1 = ANSI 150 flanges  
 3 = ANSI 300 flanges  
 A = NPT thread

**JK = Body Material**

11 = Carbon Steel w/ SS Electrodes  
 41 = 304 SS w/ SS Electrodes  
 51 = 316 SS w/ SS Electrodes  
 91 = Polypropylene w/ SS Electrodes

**L = Electronics Enclosure Mounting Configuration**

1 = Integral  
 2 = Remote

**TRANSMITTER CONFIGURATION INFORMATION**

**BC = Outputs**

10 = One (1) AO, two (2) DO and one (1) DI  
 11 = One (1) AO, two (2) DO and one (1) DI  
 w/ MODBUS (RS485)

**E = Input Power**

1 = Low power, 24 VAC/VDC  
 2 = High power, 120 - 240 VAC

**D = Electronics Enclosure**

1 = IP67 (NEMA 4X) enclosure w/ display

**1.7 ADDITIONAL HARDWARE THAT MAY BE REQUIRED**

**1.7.1 Grounding Rings**

Grounding rings may be required whenever meters are installed in non-metallic or lined pipes. Grounding rings placed before and after the meter eliminate electrical noise that will interfere with the proper operation of the meter. ONICON provides grounding rings as an optional accessory.

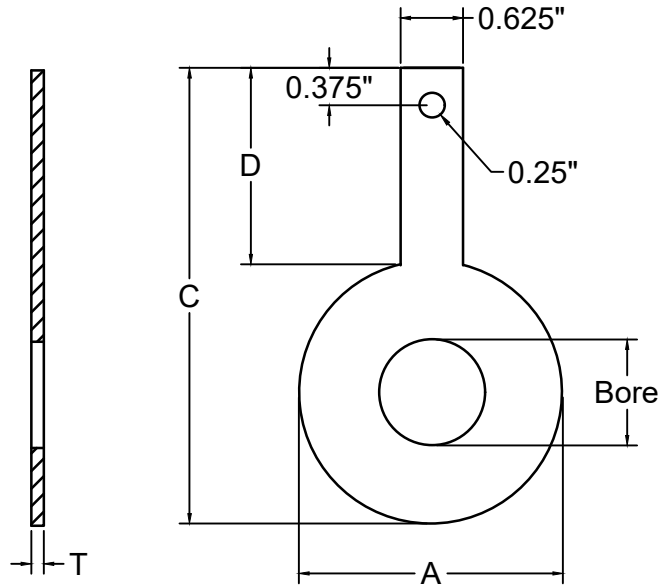

ANSI Class 150 Grounding Ring Dimensions					
Nominal Size	Bore	A	C	D	T
1"	1 - 1/16	2 - 5/8	4 - 9/16	1 - 15/16	1/8
1.5"	1 - 9/16	3 - 3/8	5 - 5/16	1 - 15/16	1/8
2"	2 - 1/16	4 - 1/8	6 - 1/16	1 - 15/16	1/8
3"	3 - 1/16	5 - 3/8	7 - 5/16	1 - 15/16	1/8
4"	4 - 1/16	6 - 7/8	8 - 13/16	1 - 15/16	1/8
6"	6	8 - 3/4	10 - 11/16	1 - 15/16	1/8
8"	8	11	12 - 15/16	1 - 15/16	1/8
10"	9 - 1/2	13 - 3/8	15 - 5/8	2 - 1/4	1/8
12"	11 - 9/16	16 - 1/8	18 - 9/16	2 - 7/16	1/8
14"	13 - 1/2	17 - 3/4	20 - 3/8	2 - 5/8	1/8
16"	15 - 1/4	20 - 1/4	22 - 7/8	2 - 5/8	1/8
18"	17 - 3/8	21 - 5/8	24 - 1/4	2 - 5/8	1/8
20"	19	23 - 7/8	26 - 11/16	2 - 13/16	1/8
24"	23	28 - 1/4	31 - 1/8	2 - 7/8	1/8

### 1.7.2 Gaskets

Gaskets are required for sensor bodies with ebonite and polypropylene liners and are strongly recommended for meters with PTFE liners. Gasket dimensions must comply with ASME B16.5 flange standards. ONICON does not supply gaskets for this product.

The following general suggestions are provided to assist the installer in choosing the proper gasket material. In all cases, the responsibility of selecting the appropriate material rests with the installer.

Gaskets are used to create a seal between the flow meter liner surface and the surface of the mating flange. The proper choice of gasket material will allow for a leak free connection at the time of installation and maintain that seal over time. How well the gasket works depends on a number of factors. Each of these should be considered when choosing a gasket material.

Is it chemically compatible with the fluid?

- Will it withstand the expected minimum and maximum operating temperatures?
- Does it provide enough resiliency and creep resistance to maintain loading over time?
- Will it deform enough to create a seal by filling imperfections in the sealing surfaces?
- Is it thick enough to take up variations in flatness of the surface?

In many cases a simple 1/8" red rubber gasket with a Shore A hardness (Durometer) of 60 – 80 will suffice. Your local gasket supplier should be able to guide you in selecting the best material for your application.

## 1.8 WORKING ENVIRONMENT

The FT-3100 was designed for installation and use in typical industrial environments that are free of corrosive liquids and fumes, direct liquid exposure, direct sunlight, temperature extremes and vibrations.

The operating ambient air temperature range is 14°F to 140°F.

The electrical power should be relatively clean, free of high frequency noise, large voltage transients, and protected from power surges and brown outs.

## 1.9 SERIAL NUMBER

The FT-3100 has two separate serial numbers. The transmitter serial number is located on the identification plate located on the electronics enclosure. The sensor serial number is located on the identification plate located on the sensor body.



## SECTION 2.0 UNPACKING

The FT-3100 is generally shipped in one package unless optional hardware or equipment is ordered. Notify the freight carrier and ONICON's Customer Service Department if any items are damaged in transit.

### 2.1 DOCUMENTATION

Enclosed with each FT-3100 is a comprehensive documentation package that includes the following items:

Certificate of Calibration

The Installation and Operation Guide is available at [www.onicon.com](http://www.onicon.com)

### 2.2 TRANSMITTER CONFIGURATION

- **Integral Mount Transmitter**

FT-3100 Inline Electromagnetic Flow Meters with integrally mounted transmitters are shipped fully assembled. Remove the meter from the shipping carton and inspect it for physical damage.

- **Remote Mount Transmitter**

FT-3100 Inline Electromagnetic Flow Meters ordered with the remote transmitter mounting option will be shipped in one carton that contains the flow sensor body, the transmitter with mounting hardware and the necessary cable to connect the two together. Remove each and inspect for physical damage.

#### **IMPORTANT NOTE**

***FT-3100 transmitters and sensor bodies are two parts of one uniquely calibrated system and must be installed together. Mixing components from other systems will result in significant calibration errors.***

2.3 ACCESSORIES

- **Grounding Rings**

Grounding rings are optional accessories that may be required for proper installation. Grounding rings may be shipped in a separate carton. Remove each and inspect it for physical damage.

- **Remote Cable**

Remote cable is typically shipped in the same carton that contains the flow sensor body and the transmitter with mounting hardware. Remove each and inspect it for physical damage.

- **Peripheral Equipment**

BTU meters or display modules ordered with an FT-3000 Series Electromagnetic Flow Meter will be packaged in a separate carton and delivered configured, calibrated, and programmed for use together as a complete system.

The FT-3100 serial number and the peripheral device serial number will be shown on the certificate of calibration and on the BTU display.

<b>FLOW METER CERTIFICATE OF CALIBRATION</b>		 <small>Flow and Energy Measurement</small>
<b>CALIBRATION &amp; CONFIGURATION DATA for FT-3000 SERIES MAGNETIC FLOW METERS</b>		
<b>METER DATA</b>		<b>CALIBRATION OF PRIMARY FLOW ELEMENT</b>
Meter Tag:	<b>CH2-F</b>	Ka factor: <b>1.5</b>
Model:	<b>FT-3106-11111-1011</b>	Medium: <b>Water</b>
Serial Number:	<b>001019461</b>	Primary Calibration Date: <b>12/8/2018</b>
Component S/N's:	<b>123456                      123456</b>	
Meter Size:	<b>6"</b>	
Max. Operating Pressure:	<b>225 PSI</b>	
Max. Operating Temperature:	<b>212 F</b>	
Connections:	<b>ANSI 150 Flanges</b>	
Peripheral Device Serial Number:	<b>001XXXX</b>	
<div style="border: 1px solid black; padding: 5px; width: fit-content; margin: 0 auto;"> <b>ONICON certifies that this flow meter was calibrated in accordance with ISO 9104:1991 and ISO 17025:2005 using standards that are directly traceable to international standards.</b> </div>		
<b>FACTORY PROGRAMMED OUTPUT SIGNALS</b>		
<small>(Performed at ONICON Factory; can be reprogrammed in the field)</small>		
Analog Flow Range: 4-20 mA = 0 to:	<b>1000</b>	<b>GPM</b>
Frequency Output Meter Factor:	<b>10</b>	<b>ppG</b>
Scaled Pulse Output: 1 Pulse =	<b>100</b>	<b>GALLONS</b>
Programmed By: <u>          <b>SRG</b>          </u> Date: <b>1/21/2019</b>		
<b>11451 Belcher Road South, Largo, Florida 33773 Tel: (727)447-6140 Fax: (727)442-5699</b>		

## SECTION 3.0 INSTALLATION

The FT-3100 Inline Electromagnetic Flow Meter should be installed by experienced contractors with related knowledge and experience in hydronic heating and cooling systems, and fluid metering applications in general. Contact ONICON for installation assistance.

The installer should use good trade practices and must adhere to all state and local building or other applicable codes.

### 3.1 SITE SELECTION

Careful attention during the site selection process will help the installers with the initial installation, reduce start-up problems, and make future maintenance easier.

When selecting a site for mounting, consider the criteria under Section 1.7 WORKING ENVIRONMENT, as well as the following:

#### IMPORTANT NOTE

**Proper site selection is critical to the performance of this flow meter. The flow meter must be properly located within the piping system in order to ensure an accurate flow measurement.**

#### 3.1.1 General Guidelines

Install the location with the longest straight unobstructed run of pipe, keeping in mind that in some applications it may be possible to locate the meter in either the supply or return pipe.



Model:	FT-3102-11111-1011
S/N:	001028564
Size:	2" (DN50)
Location:	FM-5
Liner:	PTFE
Flange:	ANSI 150 Flanges
Ka / Kz:	-1.5/-140
Fluid T.:	0 – 212 °F
Max P.:	225 PSI
Electrodes:	(3) 316 SS
Rating:	IP67
Assembly:	123456/AB123456

#### 3.1.2 Flow Direction

FT-3100 flow meters are inherently bi-directional and changes in flow direction are indicated by a change in polarity of the sensing signal. In order for the meter to display the correct polarity, it is necessary to orient the meter relative to flow direction during the installation process. The sign of the flow rate is positive when the flow direction is from – to + as printed on the tag plate as shown below. Prior to installation, determine the direction of flow in the piping system and orient the meter accordingly.

#### IMPORTANT NOTE

**Flow direction is indicated by polarity symbols ( $\pm$ ) and flow totals are accumulated separately based on direction. The polarity of the flow indication may be reversed by reversing the polarity of the Ka coefficient.**



#### 3.1.3 Remote Mount Transmitter

Find an easily accessible location where wire connections can be made and meter readings can be taken from floor level. Mount the transmitter on a vibration free surface. Avoid locations that contain electric motors or other strong sources of electrical interference.

#### IMPORTANT NOTE

**The maximum distance between the transmitter and sensor body is 65ft. Contact ONICON if the transmitter needs to be more than 65ft from the sensor body.**

### 3.1.4 Minimum Straight Run Requirements

The straight run requirements presented below represent the minimum requirements for accurate flow measurement. For optimum performance, provide as much additional straight run as possible.

#### RECOMMENDED INSTALLATIONS

①

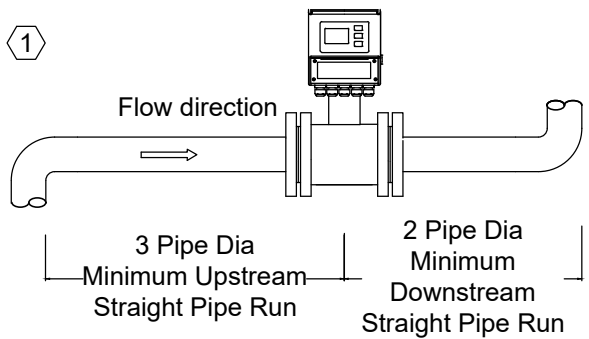

Flow direction

3 Pipe Dia Minimum Upstream Straight Pipe Run

2 Pipe Dia Minimum Downstream Straight Pipe Run

Locate flow meter in a straight run of pipe, free of bends, tees, valves and other obstructions.

②

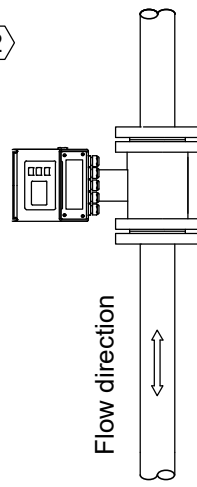

Flow direction

Installation of flow meter in vertical pipe runs with upward or downward flow is acceptable, provided the system is pressurized (closed loop).

③

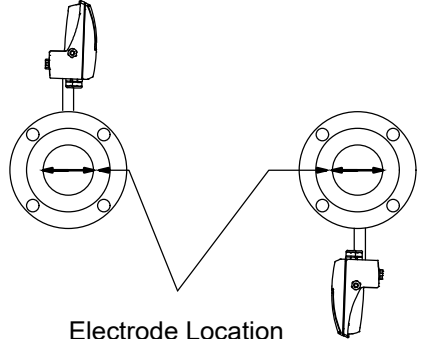

Electrode Location

Locate flow meter in horizontal pipe run with electrodes at the 3 and 9 o'clock position.

#### INSTALLATIONS TO BE AVOIDED

④

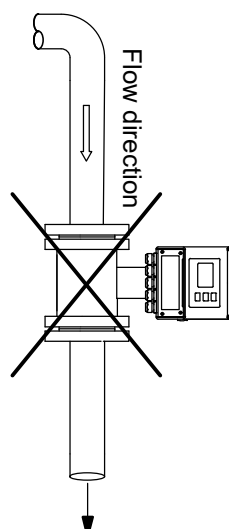

Flow direction

Avoid locating flow meter in vertical pipe run with downward flow ending in discharge to atmosphere.

⑤

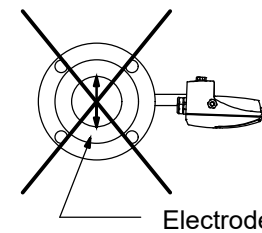

Electrode Location

Sediment or entrained air can affect the electrodes in the 12 and 6 o'clock position.

3.2 MECHANICAL INSTALLATION

**IMPORTANT NOTE**

*FT-3100 transmitters and sensor bodies are two parts of one uniquely calibrated system and must be installed together. Mixing components from other systems will result in significant calibration errors.*

3.2.1 Standard Transmitter Dimensions

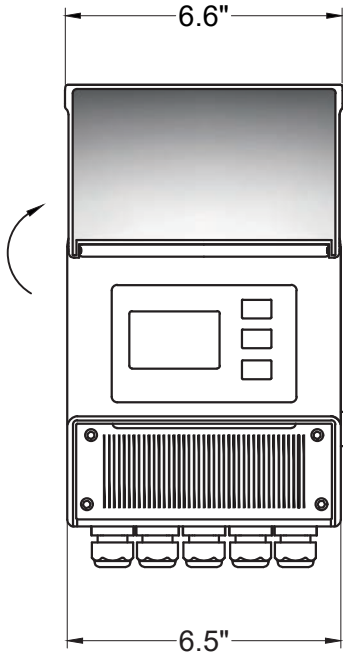

Front View - Vertical

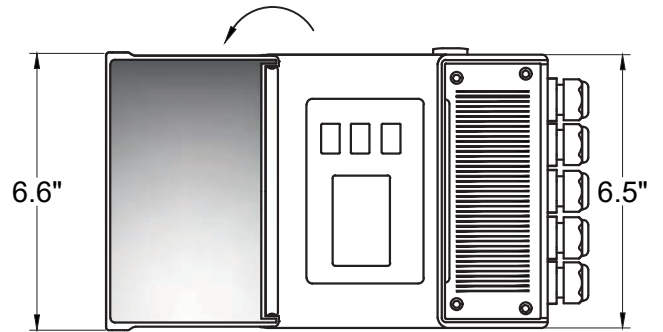

Front View - Horizontal

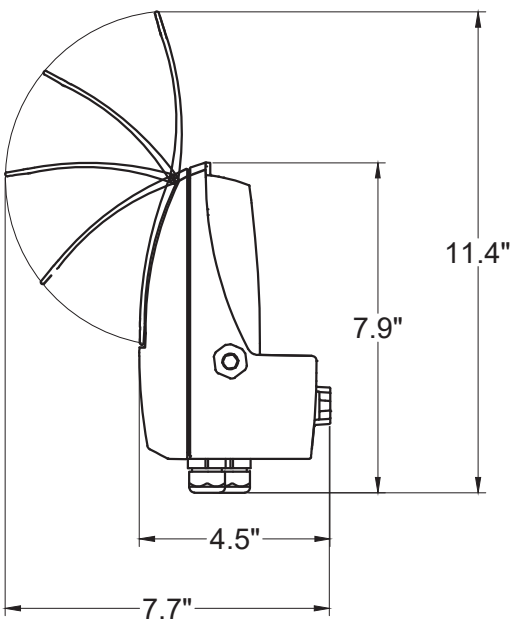

Side View

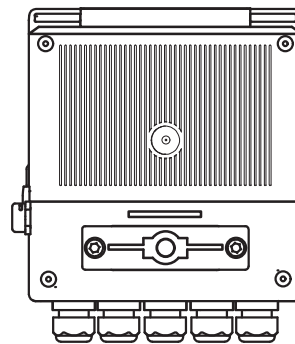

Back View

3.2.2 Sensor Dimensions & Weights

FLANGED SENSOR OVERALL DIMENSIONS

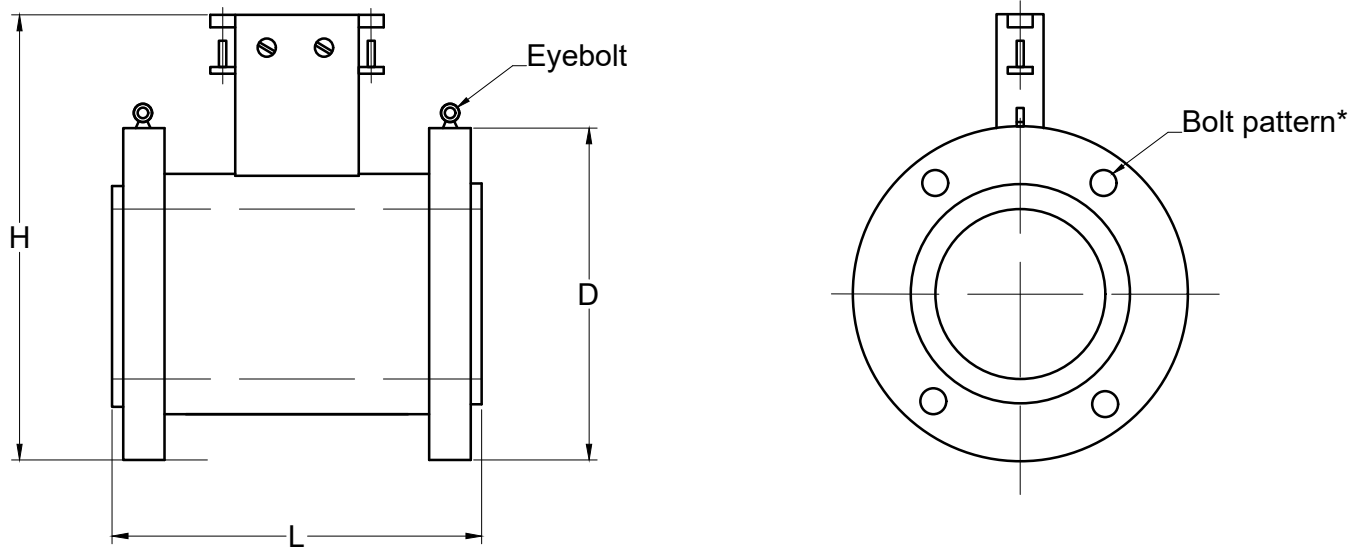

\* Bolt pattern is dependent on the type and size of the flanges

ANSI Class 150 Flanged Sensor Size																
Nominal Diameter	1"	1.5"	2"	2.5"	3"	4"	5"	6"	8"	10"	12"	14"	16"	18"	20"	24"
Length (L)	7.87	7.87	7.87	7.87	7.87	9.84	9.84	11.81	13.78	17.72	19.68	21.65	23.62	23.62	23.62	23.62
Height (H)	7.13	8.15	8.74	9.64	10.20	11.34	12.40	13.143	15.79	18.15	20.75	22.91	25.16	27.08	29.57	34.09
Flange Dia (D)	4.24	5	5.98	7	7.52	9.02	10	10.98	13.50	15.98	19.02	20.98	23.50	25	27.52	32.01
Weight in lbs	6.60	7.70	13.20	17.60	24.20	35.20	39.60	57.20	88	132	220	275	396	484	550	650

ANSI Class 300 Flanged Sensor Size													
Nominal Diameter	1"	1.5"	2"	2.5	3"	4"	5"	6"	8"	10"	12"	14"	16"
Length (L)	7.87	7.87	7.87	7.87	7.87	9.84	9.84	11.81	13.78	17.72	19.68	21.65	23.62
Height (H)	7.48	8.70	8.98	9.88	10.55	11.81	12.91	14.17	16.54	18.90	21.50	32.90	26.14
Flange Dia (D)	4.88	6.14	6.50	7.52	8.27	10	10.98	12.52	15	17.52	20.51	22.99	25.51
Weight in lbs	11	15.40	19.80	24.20	28.60	44	52.80	66	154	220	286	396	528

**WARNING**

*Eyebolts are provided to assist in the safe installation of meters with a nominal diameter greater than six inches. The eyebolts are only designed to hold the weight of the meter. DO NOT attempt to place an additional load on the eyebolts during installation.*

**WAFER STYLE SENSOR DIMENSIONS & WEIGHTS**

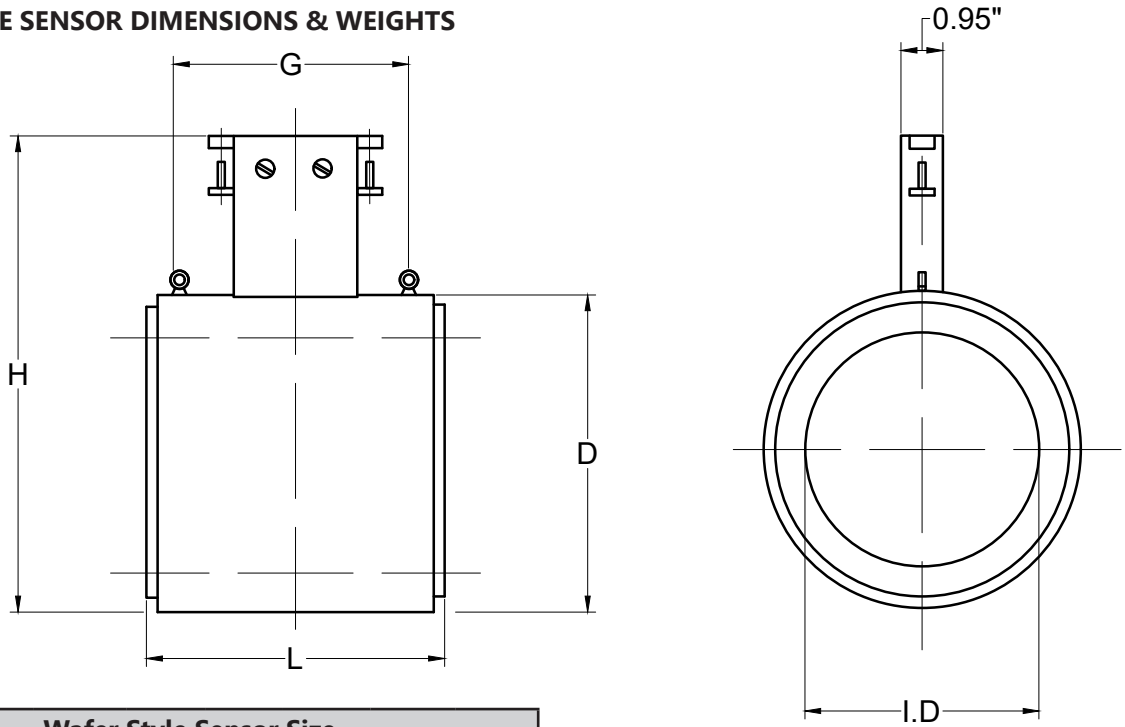

Wafer Style Sensor Size						
Nominal Dia	1"	1.5"	2"	2.5"	3"	4"
Length (L)	3.94	3.94	3.94	5.90	5.90	5.90
Height (H)	5.79	6.34	6.97	7.83	8.23	9.25
Wafer Dia (D)	2.20	2.76	3.39	4.25	4.65	5.67
Net Weight in lbs	2.60	4	4.40	7.90	8.40	11

**THREADED STYLE SENSOR DIMENSIONS & WEIGHTS**

	Polypropylene	Stainless Steel
L	5.50"	4.72"
H	7.40"	6.69"
W	3.80"	3.07"
Weight in lbs	4.85	4.85

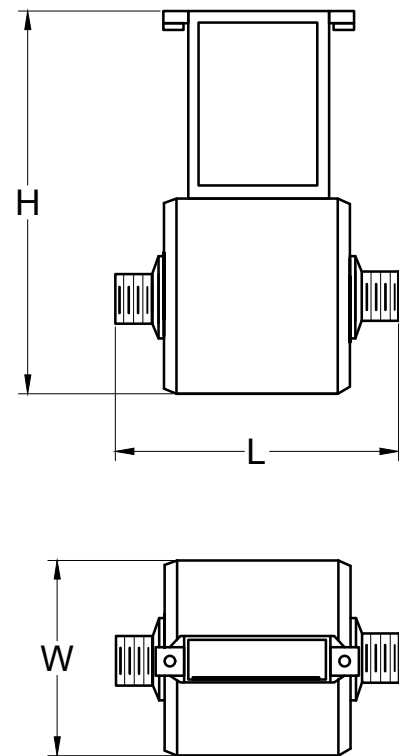

### 3.2.3 Installation Drawings for Conductive Pipe

#### FLANGE STYLE INSTALLATION IN CONDUCTIVE PIPE

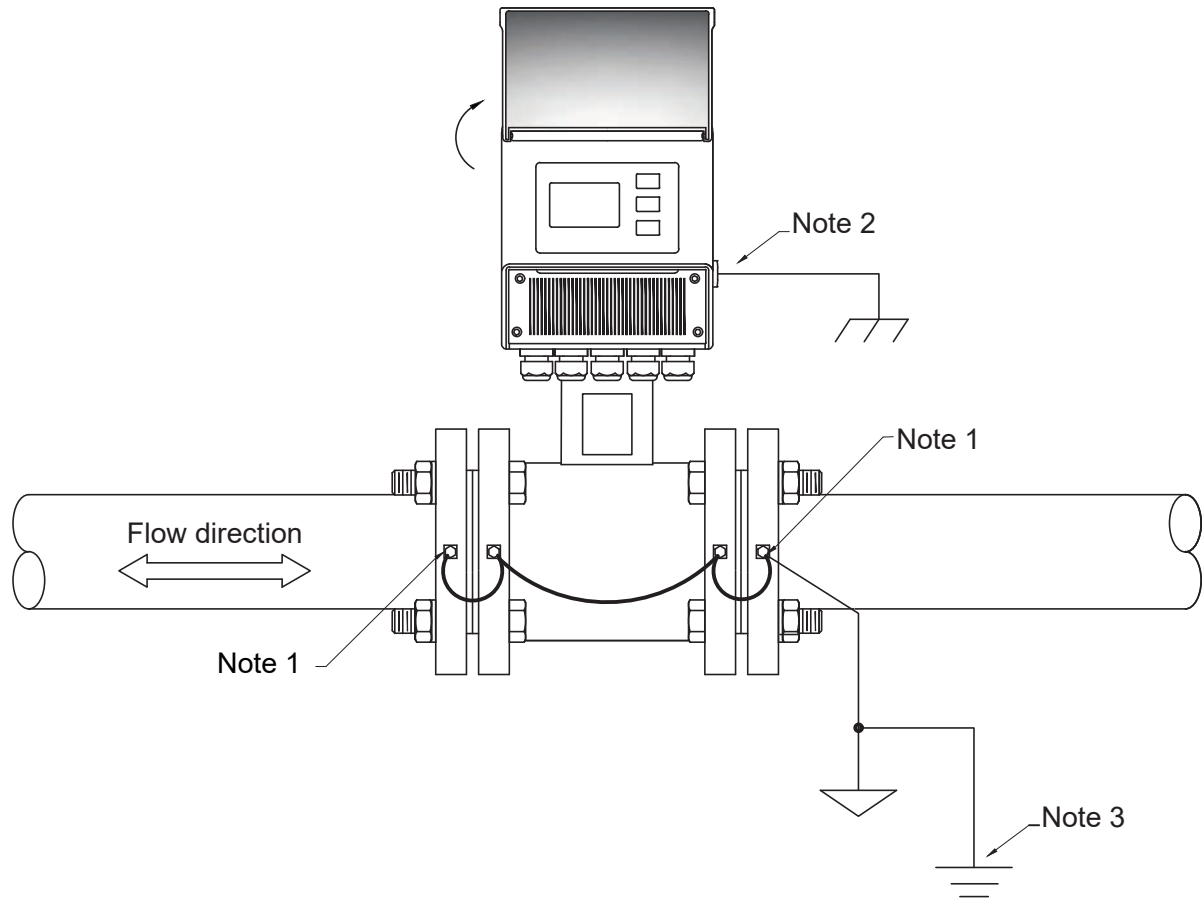

#### NOTES

1. Using a #21 (0.159") drill bit, drill a 1/2" deep hole in edge of each mating flange. Tap each hole using a 10-32 tap. Secure the ring connectors (provided) and grounding wires to the flange using the green grounding screws (provided). (Alternate method: Weld 10-studs (not provided) to the flange faces and attach ring connectors with 10-32 nuts (not provided).
2. Provide a ground connection at the input power terminals inside the transmitter enclosure.
3. Provide a quality earth ground connection to the meter. From best to worst, grounding options include:
  - Earth grounding rod driven into the ground.
  - Earth wire connected directly to the building electrical service panel.

#### CAUTION

***The earth connections must be made as shown. Failure to do so will result in erratic operation of the meter.***



## WAFER STYLE INSTALLATION IN CONDUCTIVE PIPE

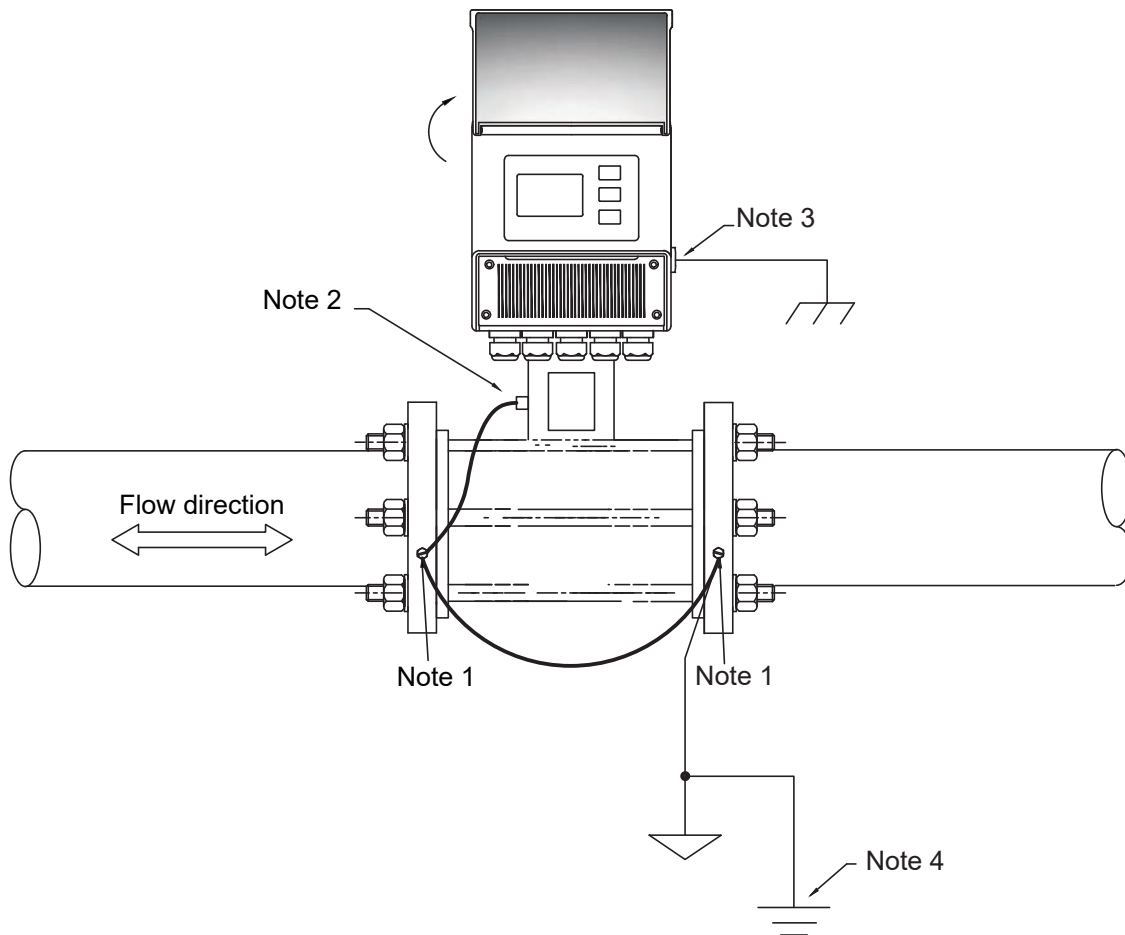

### NOTES:

1. Using a #21 (0.159") drill bit, drill a 1/2" deep hole in edge of each mating flange. Tap each hole using 32 tap. Secure the ring connectors (provided) and grounding wires to the flange using the green grounding screws (provided). (Alternate method: Weld 10-32 studs (not provided) to the flange faces and attach ring connectors with 10-32 nuts (not provided).
2. Connect grounding wire to terminal on the meter neck as shown.
3. Provide a ground connection at the input power terminals inside the transmitter enclosure.
4. From best to worst, grounding options include:
  - Earth grounding rod driven into the ground.
  - Earth wire connected directly to the building electrical service panel.

### CAUTION

***The earth connections must be made as shown. Failure to do so will result in erratic operation of the meter.***

### 3.2.4 Installation Drawing for Non-Conductive Pipe

#### FLANGE STYLE INSTALLATION IN NON-CONDUCTIVE PIPE

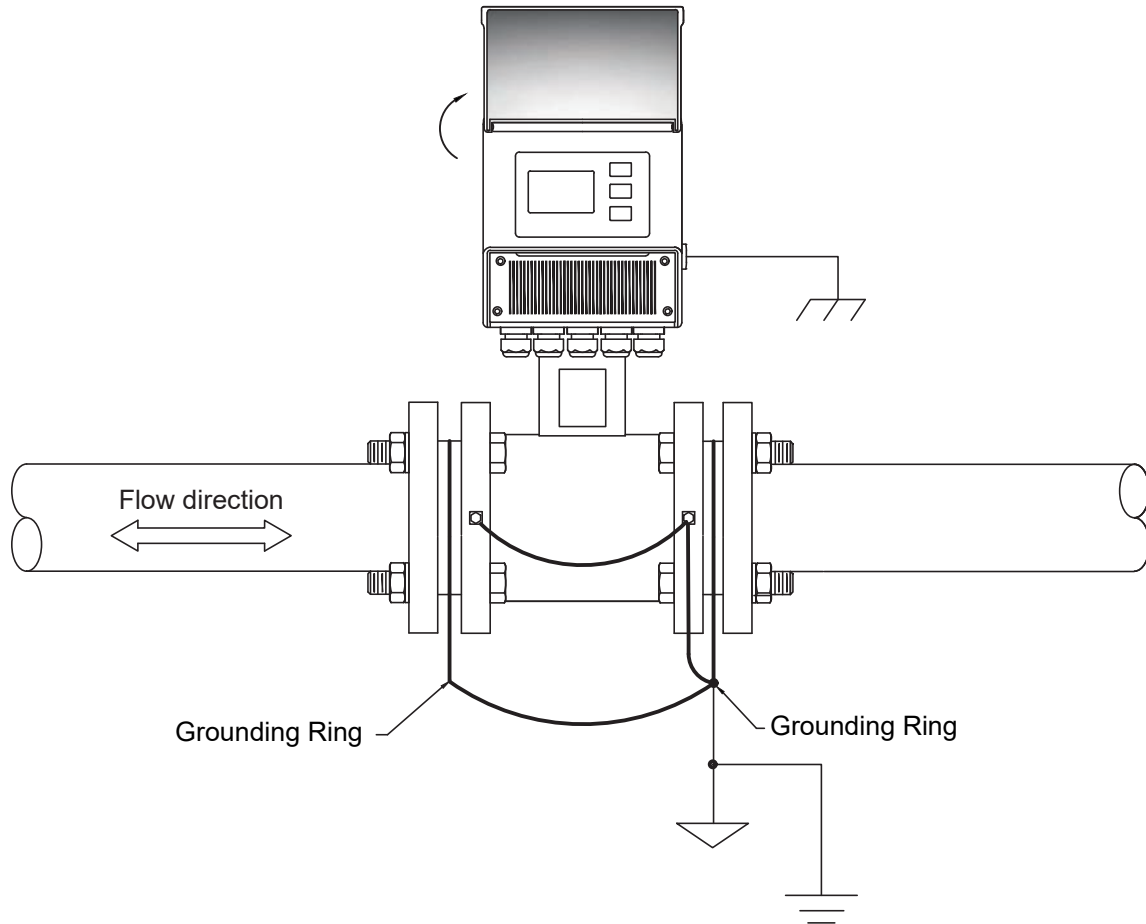

#### **CAUTION**

***The earth connections must be made as shown. Failure to do so will result in erratic operation of the meter.***

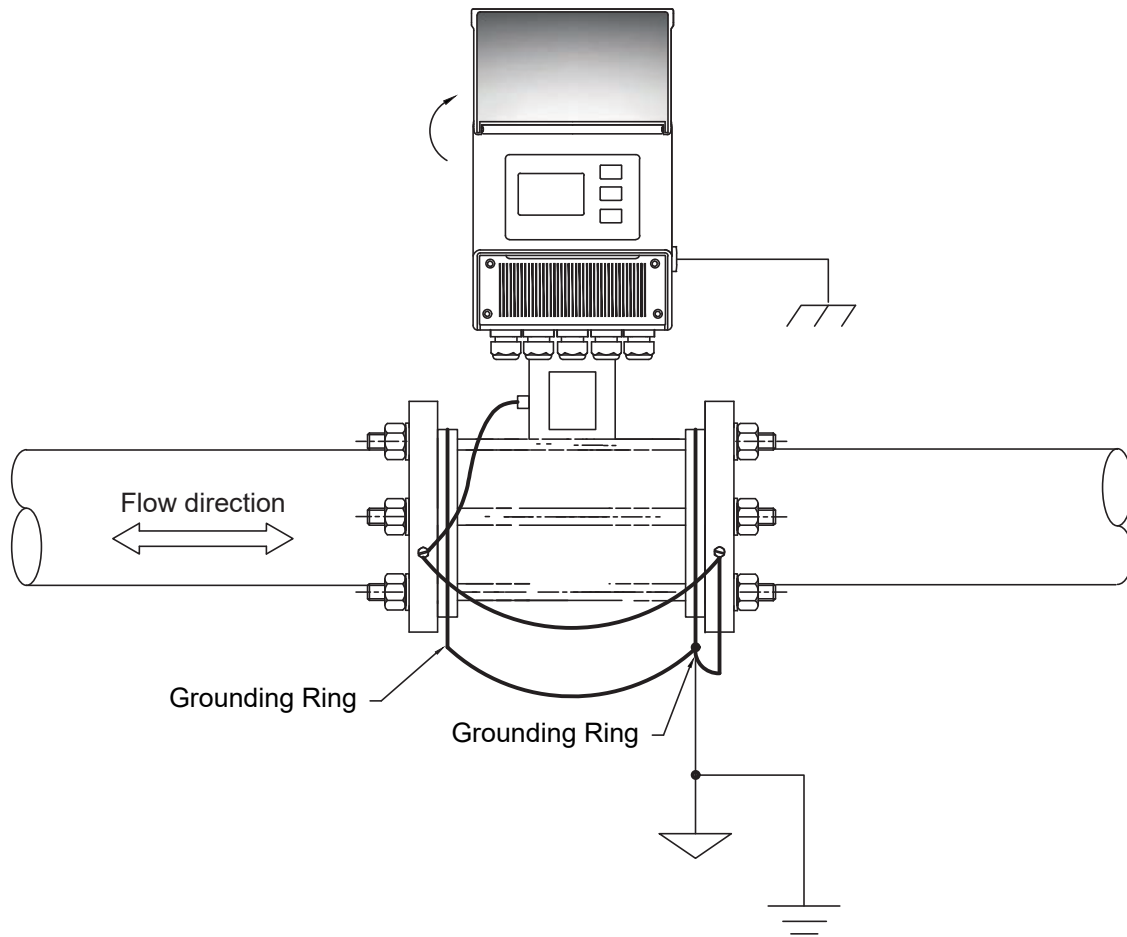
**WAFER INSTALLATION IN NON-CONDUCTIVE PIPE****CAUTION**

*The earth connections must be made as shown. Failure to do so will result in erratic operation of the meter.*

### 3.2.5 Installation Drawing for Threaded Connections

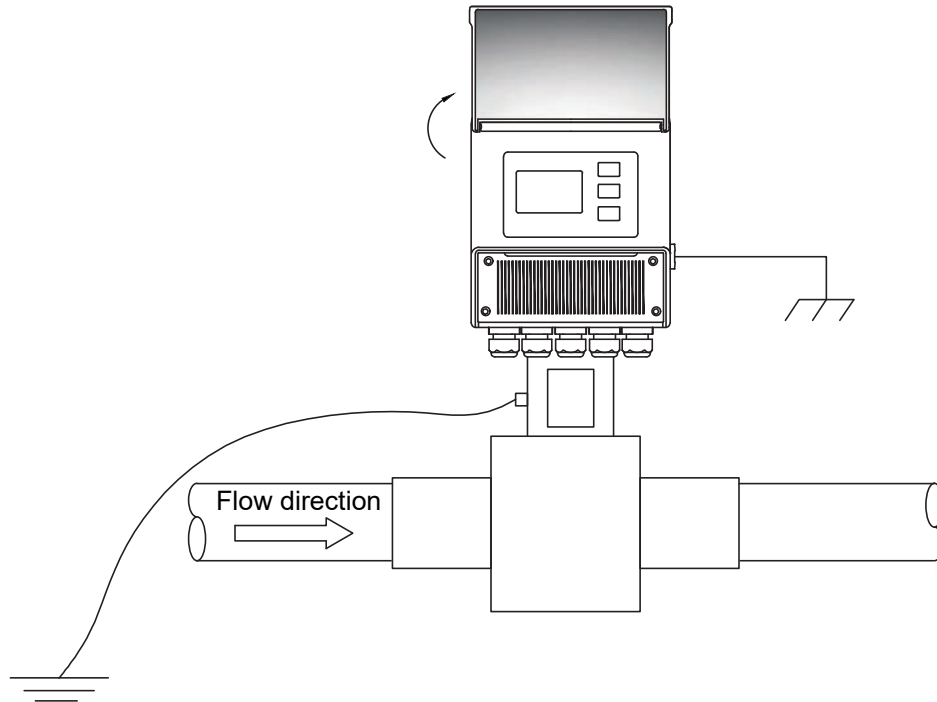

**NOTE:**

Connect grounding wire to terminal on the meter neck as shown.

**CAUTION**

*The earth connections must be made as shown. Failure to do so will result in erratic operation of the meter.*

3.2.6 Installation Instructions

**WARNING**

*Installation of this product should only be attempted by qualified tradespersons and must comply with all local, state and federal building codes.*



1. Thoroughly clean all flange surfaces removing all traces of any old gasket material or any adhesive residue.
2. Inspect all flange surfaces for warping, pitting or other surface imperfections that may prevent a good seal.
3. Use new bolts, nuts and hardened washers. ONICON recommends the use of B7 nuts, bolts and washers. Prior to installation, lubricate the bolt threads, nuts, washer faces and the underside of the bolt head with lubricant (Fel Pro C5A or equivalent). This lubricant is necessary to ensure uniform stress distribution on the sealing surface. Use care not to get any lubricant on the liner or gasket material.
4. Center the new gasket on the liner surface. Do not allow the gasket to protrude into the flow stream.
5. Use the torque specifications shown below to determine the recommended final bolt torque requirements.
6. Using a torque wrench, tighten the bolts in at least three stages (30%, 60% & 100%) using a repeating pattern sequence shown in the diagrams below.

**FLANGE BOLT TIGHTENING SEQUENCE**

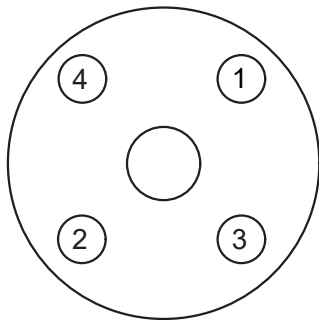

4-bolt

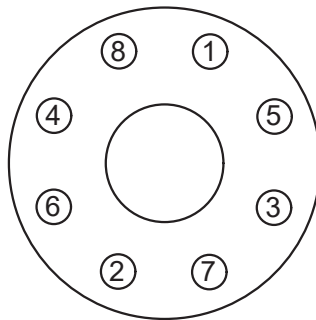

8-bolt

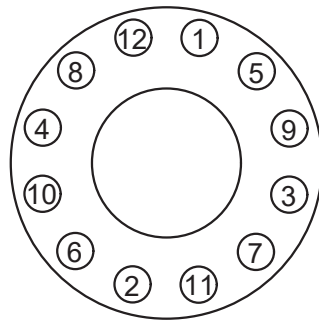

12-bolt

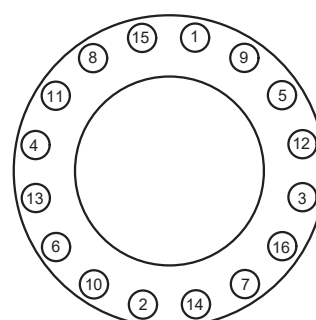

16-bolt

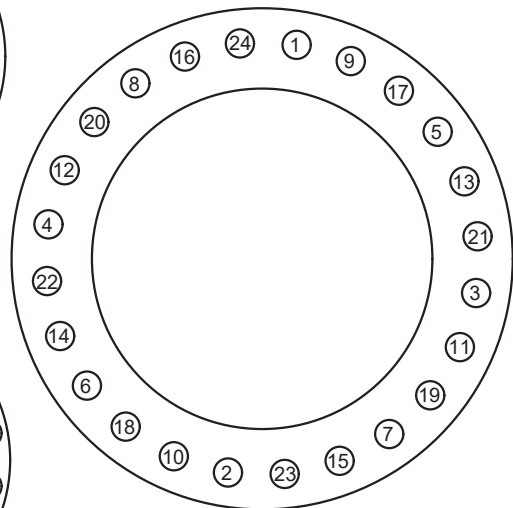

24-bolt

### 3.2.7 Torque Specifications

Tighten uniformly in a diagonal sequence as per the table below. Contact ONICON for torque specifications for meters with a nominal diameter larger than 24 inches.

Maximum Flange Bolt Torque Specifications in lb/ft (N-m)										
Nom. Dia. (DN)	Class 150			Class 300		PN16			PN25	
	Polypro	Ebonite	PTFE	Ebonite	PTFE	Polypro	Ebonite	PTFE	Ebonite	PTFE
1" (25)	14		15		24	14 (19)		18 (25)		18 (25)
1¼" (32)	21		19		30	21 (28)		32 (43)		32 (43)
1½" (40)	27		24		46	27 (36)		39 (53)		39 (53)
2" (50)	38		44		26	38 (52)		50 (68)		50 (68)
2½" (65)	55		58		39	55 (75)		66 (90)		33 (45)
3" (80)	30		66		50	30 (41)		39 (53)		39 (53)
4" (100)	41		52		69	41 (56)		44 (59)		61 (83)
5" (125)	52		69		96	52 (71)		57 (77)		83 (112)
6" (150)	78		78		83	78 (106)		80 (108)		100 (135)
8" (200)		319	109	383	131		212 (288)	73 (99)	288 (391)	99 (134)
10" (250)		336	115	398	136		301 (408)	103 (140)	439 (595)	150 (204)
12" (300)		504	173	592	203		376 (510)	129 (175)	434 (588)	148 (201)
14" (350)		698	240	684	235		441 (598)	151 (205)	697 (945)	239 (324)
16" (400)		672	230	884	303		606 (821)	208 (282)	917 (1243)	314 (426)
18" (450)		683	248	856	294		724 (981)	207 (281)		
20" (500)		682	234	1000	343		821 (1113)	282 (382)		
24" (600)		996	342	1665	571		1223 (1658)	419 (568)		

Maximum Flange Bolt Torque Specifications in lb/ft					
Nom. Dia. (DN)	PN10		PN40		PN64
	Ebonite	PTFE	Ebonite	PTFE	Ebonite
1" (25)					18 (25)
1¼" (32)					29 (39)
1½" (40)					32 (43)
2" (50)					39 (53)
2½" (65)					53 (72)
3" (80)					60 (81)
4" (100)					50 (68)
5" (125)					33 (45)
6" (150)					43 (58)
8" (200)					39 (53)
10" (250)					46 (62)
12" (300)					61 (83)
14" (350)					83 (112)
16" (400)					109 (148)
18" (450)					160 (217)
20" (500)	319 (432)	109 (148)	384 (391)	131 (178)	
24" (600)	265 (359)	91 (123)	575 (595)	197 (267)	
	306 (415)	105 (142)	599 (588)	205 (278)	
	370 (502)	127 (172)	908 (945)	311 (422)	
	466 (632)	160 (217)	1331 (1243)	457 (619)	
	416 (564)	143 (194)			
	481 (652)	165 (224)			
	695 (942)	238 (323)			

### 3.2.8 Remote Mount Transmitter

Remote mount transmitters are provided with a single "L" bracket with two 1/4" mounting holes. The bracket is secured to the transmitter by means of a large bolt with a knurled knob for a head. To mount the bracket, first separate it from the transmitter housing and attach it to the wall or other vertical surface. Cable from the sensor body is attached to the transmitter using the center strain relief.

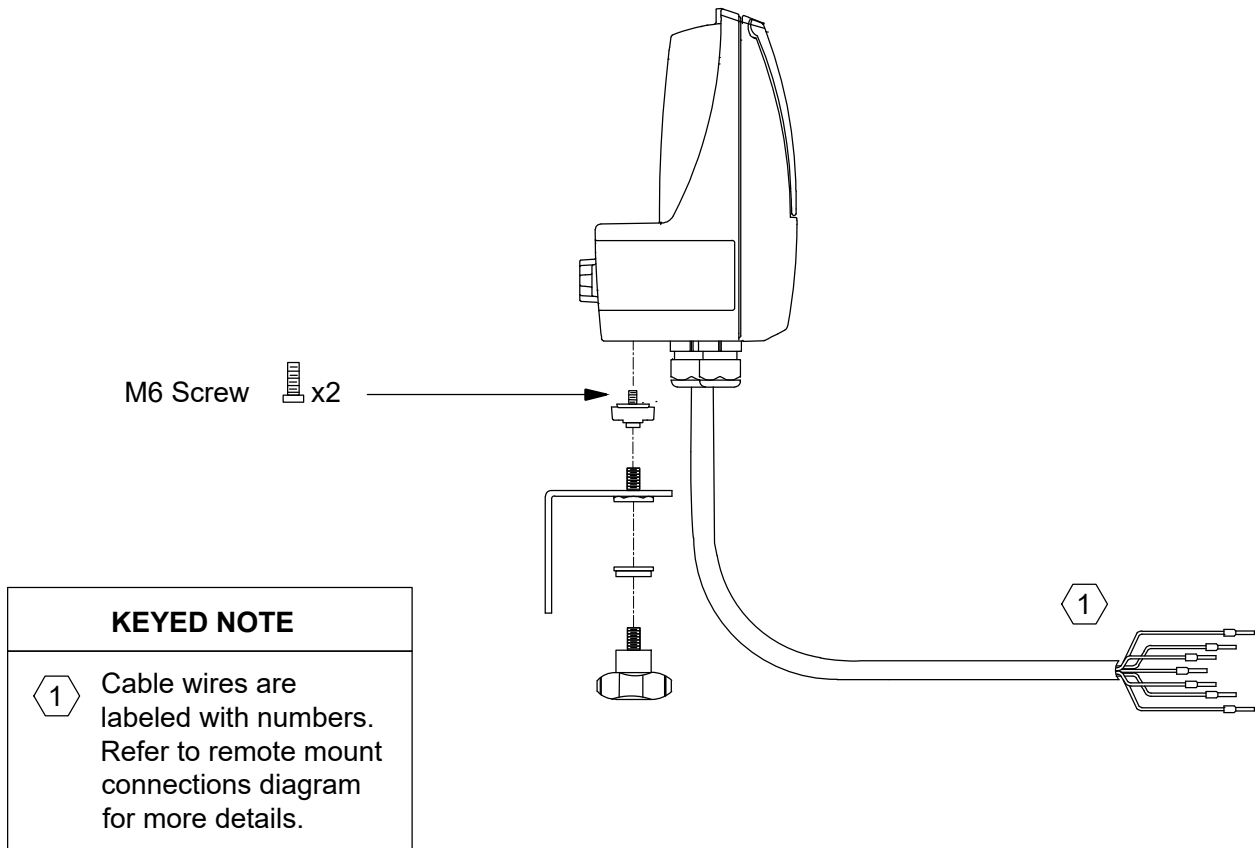

**CAUTION**

**DO NOT drill holes in the transmitter. Use only the openings that are provided. DO NOT cut the remote cable. Coil excess cable at one end.**

REMOTE MOUNT OVERALL DIMENSIONS

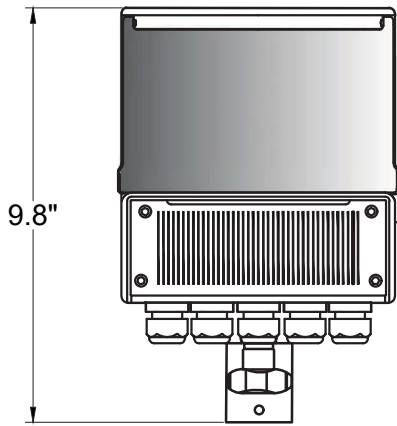

Front View

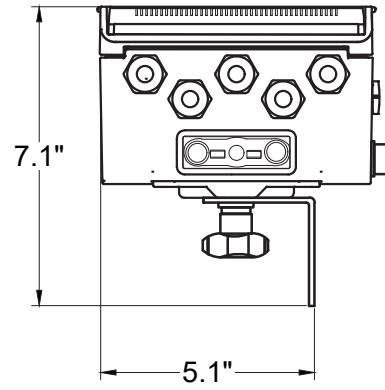

Bottom View

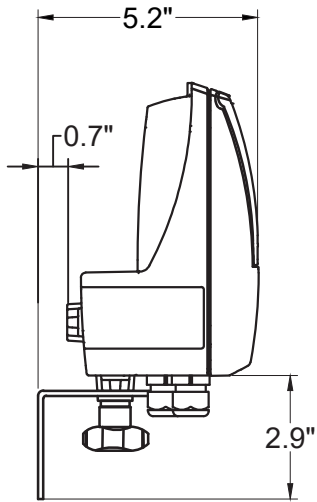

Side View

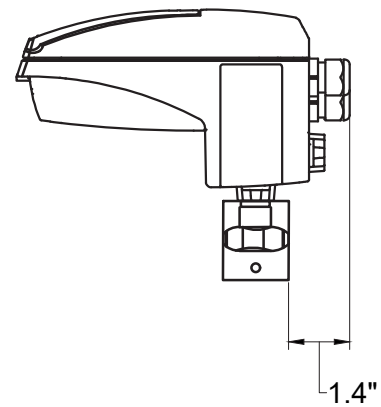

Side View



**3.3 ELECTRICAL INSTALLATION**

**3.3.1 Input Power Requirements**

FT-3100 Electromagnetic Flow Meters are provided with two different options for input power.

- Low Power, 24 VAC/DC, 50/60 Hz, 12 VA
- High Power, 120 - 240 VAC, 50/60 Hz, 12 VA

**3.3.2 Power and Output Signal Wiring Instructions**

Factory Default Output Configurations

ONICON pre-programs the analog and pulse outputs based on application specific data provided at the time the meter is ordered. The table below shows how the pulse outputs are configured based on whether the application has bi-directional flow.

Application	Digital Output #1	Digital Output #2
Single Directional Flow	Frequency Output Meter Factor PPG (Hz)	Scaled Pulse Output
Bi-directional Flow	Frequency Output Meter Factor PPG (Hz)	Flow Direction

3.3.3 Wiring Diagram

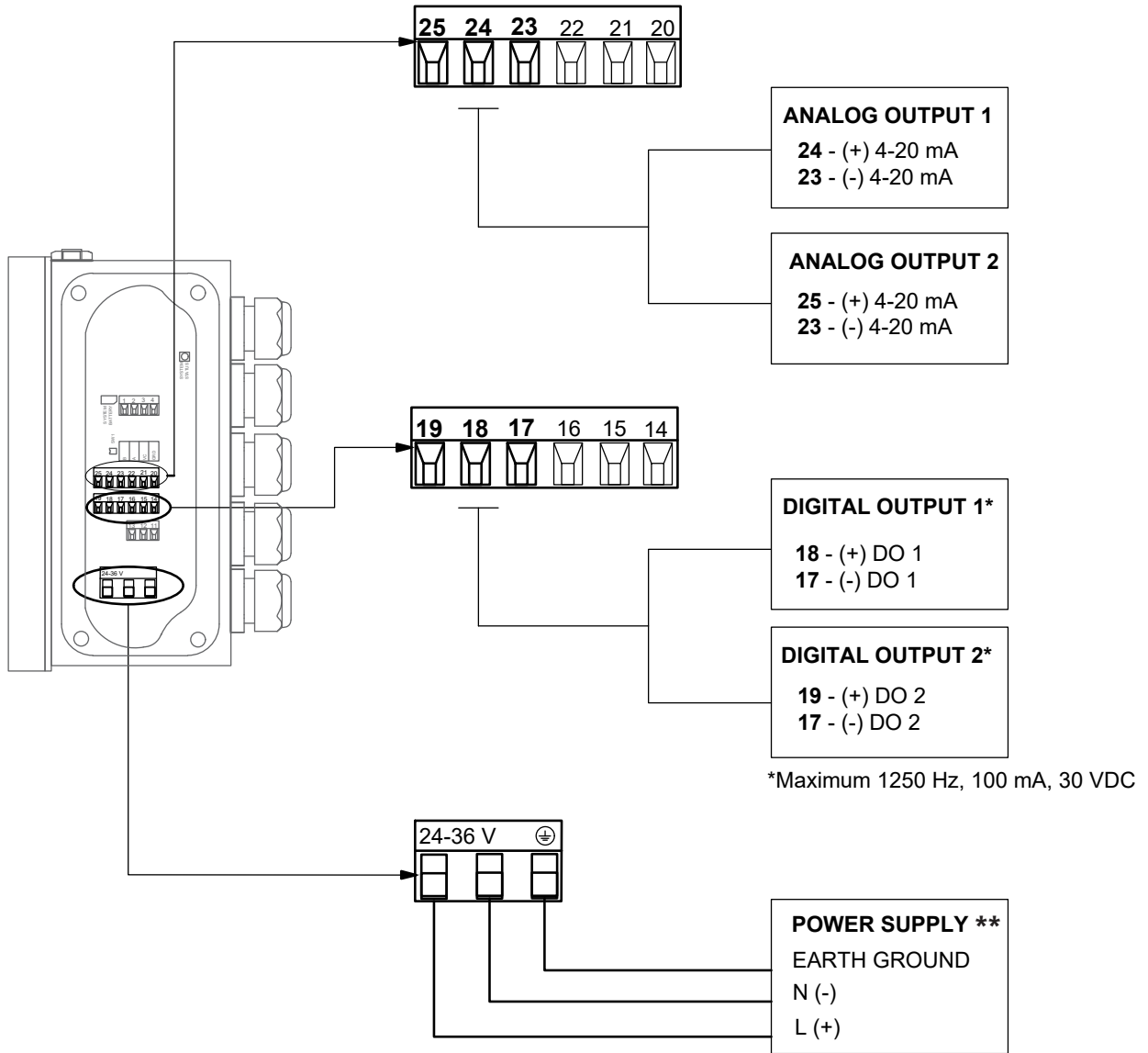

\*\* NOTE:

DIGITAL OUTPUT SCHEMATIC

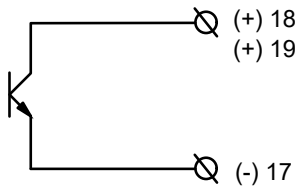

This option is not field selectable. Contact the factory if you need to change the input voltage rating. All mains voltage connections must be made through pre-drilled conduit/strain relief opening located at the bottom of the enclosure. Failure to do so will result in an increased risk of injury.

CAUTION/WARNING

*This product must be connected to earth ground for proper operation. Failure to do so will result in erratic operation and an increased risk of injury.*

**3.3.4 Earth Connection**

FT-3100 Electromagnetic Flow Meters are designed to detect microvolt signal levels at the electrodes located in the flow meter body. These signals are generated as conductive fluids flow through the magnetic field generated by the meter. If enough random electrical noise is present at the electrodes, it can interfere with the flow measurement. Care must be taken during installation to minimize the effects of electrical noise on the flow meter.

The most effective way to minimize the effects of electrical noise is to make sure that the pipe, fluid, flow meter body and flow meter transmitter are all connected to the same earth ground. This accomplishes two important goals. First, it ensures that the pipe, fluid, flow meter body and electronics are all at the same electrical potential, and second, it ensures that this electrical potential is the same as earth ground.

In order to be certain that the meter is properly connected to earth, the flow meter body earth connections (at the flanges or on the neck of wafer meters) and the transmitter earth connection should be run directly to a known earth connection. The length of this earth cable should be as short as practically possible, preferably  $\leq 25$  feet in length. The table below lists earth connections from best to worst.

**IMPORTANT NOTE**

***Non-metallic pipes are more susceptible to electrical noise. Grounding rings installed upstream and downstream of the flow meter body to reduce the electrical noise present in the pipe may be required for proper operation.***

**CAUTION**

***Do not use bolts that hold pressure to make earth connections. Using flange bolts may result in poor electrical connections due to the presence of paint and/or lubricants. Use the dedicated flange earth connections or the dedicated earth connection on the neck of wafer style meters.***

<b>Provide a quality Earth ground connection to the meter. From best to worst, grounding options include (stranded wire 14-18 AWG):</b>
Earth grounding rod driven into the ground
Earth wire connected directly to the building electrical service panel ground.

### 3.3.5 Remote Mount Cable Wiring Diagram

#### Transmitter Flow Sensor Connections

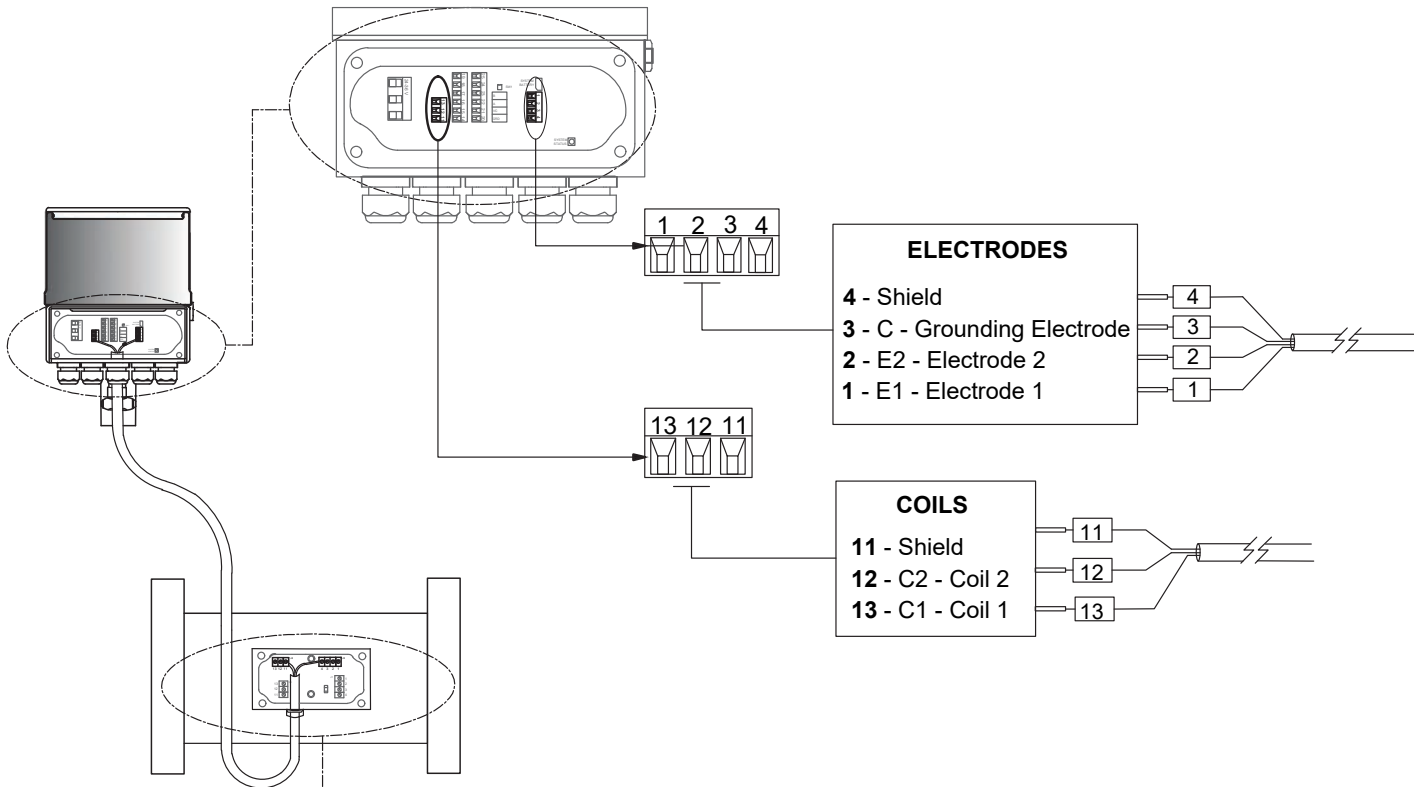

#### Body Flow Sensor Connections

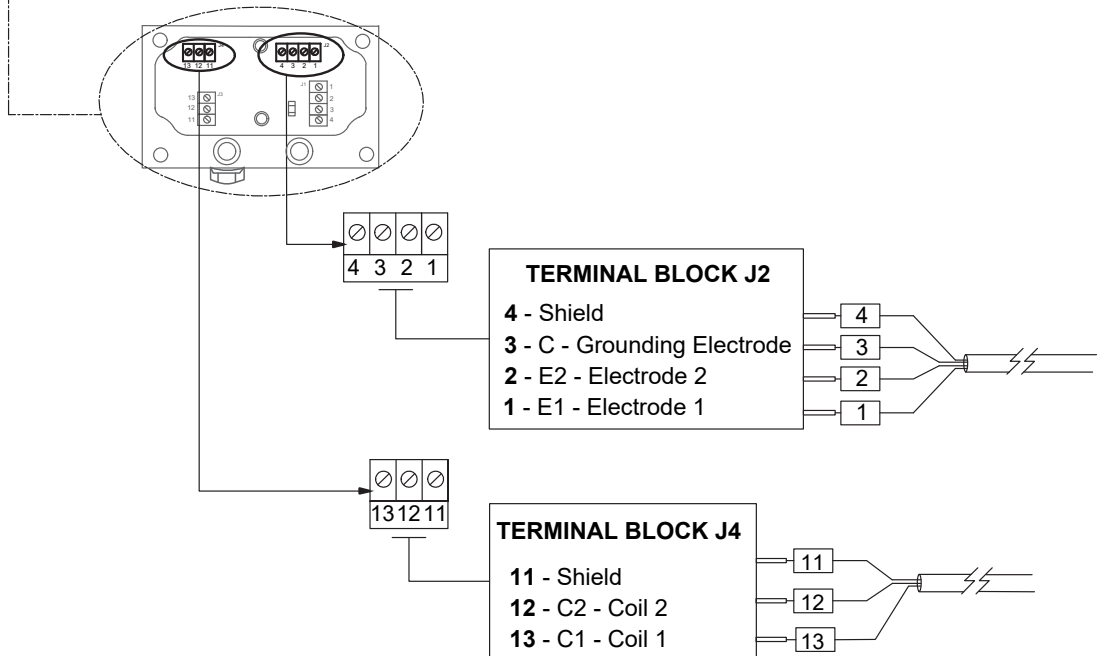

**CAUTION**

*Do not cut the remote mount cable. The wires are not color coded.*

## SECTION 4.0 METER START UP & COMMISSIONING

**4.1 DISPLAY AND USER INTERFACE** The FT-3100 transmitter is equipped with a lighted graphic display and 3-button user interface as shown below.

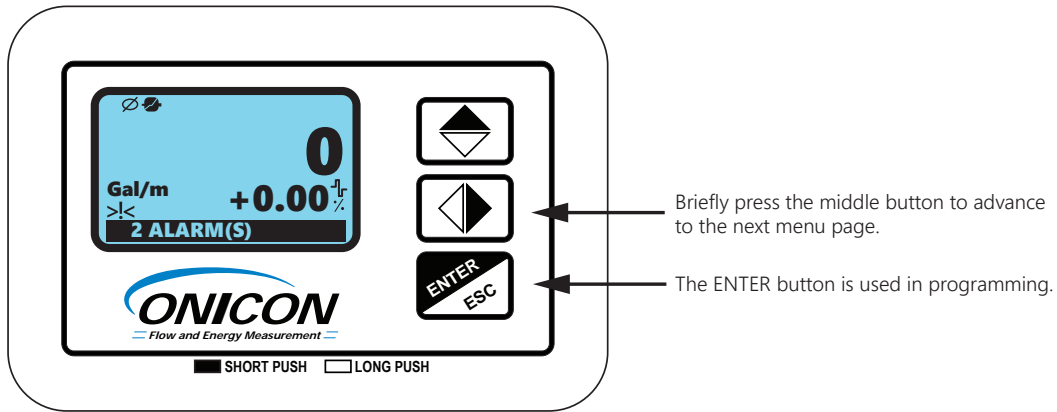

### STATUS ICONS

Icon	Description	Icon	Description
∅	Empty Pipe		Excitation Error
>K	Generic Alarm (Flashing)		General Alarm (Flashing)

A multicolored LED inside the field wiring compartment provides addition information on the operating status.

Red LED: Alarm
Blue LED: USB comm enabled
Green LED: Normal Operation

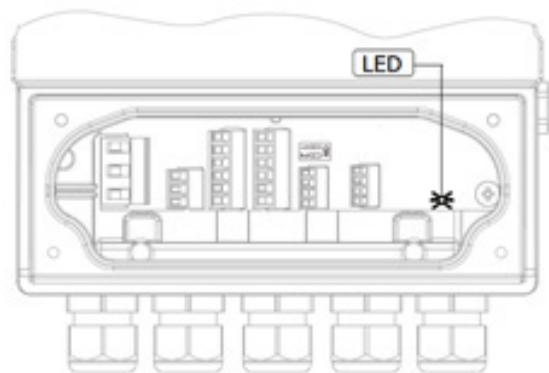

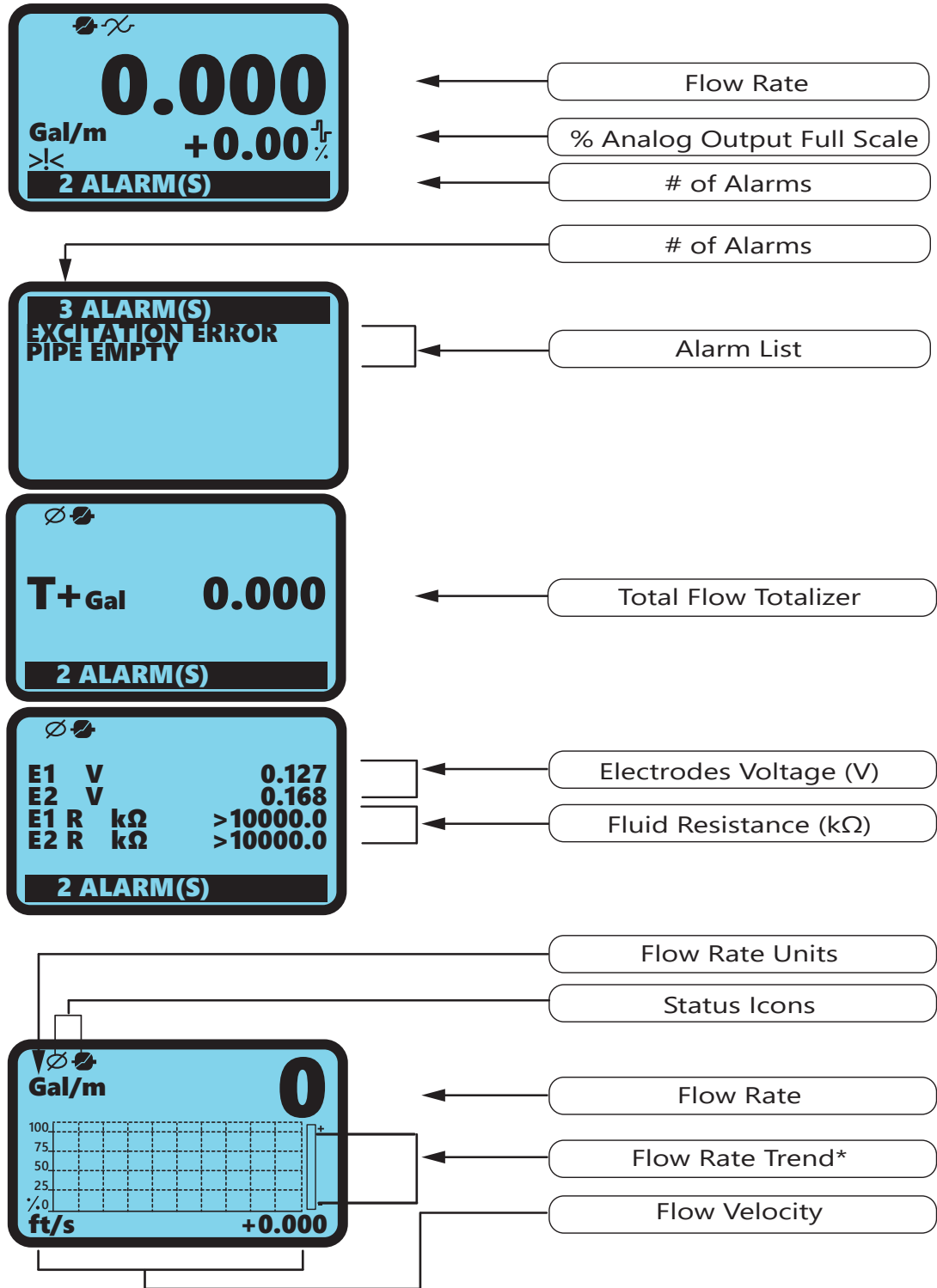

The following is a list of available menu pages. They are viewed sequentially by briefly pressing the middle button. Not all pages may be enabled on your meter.



\* Trend is a graph of the % of analog output full scale over the last 100 seconds.

**4.2 ACCESSING THE PROGRAMMING MENUS**

Access to the programming menus is password protected. The factory default access code is: 4\*\*\*\*\*. The 3-user interface pushbutton functions change when operating in the program mode. The functions are described below.

Push Button	Short Press (<1 second)	Long Press (>1 second)
	<ul style="list-style-type: none"> <li>Moves the cursor to the right on input fields</li> <li>Advances to the next menu item</li> <li>Changes the process data display</li> </ul>	<ul style="list-style-type: none"> <li>Moves the cursor to the left on input fields</li> <li>Returns to the previous menu item</li> </ul>
	<ul style="list-style-type: none"> <li>Increments the numeric value or selected parameter</li> <li>Return to the previous menu item</li> </ul>	<ul style="list-style-type: none"> <li>Decrements the numeric value</li> <li>Advances to the next menu item</li> </ul>
	<ul style="list-style-type: none"> <li>Enters or leaves the selected function</li> <li>Enters the program mode</li> </ul>	<ul style="list-style-type: none"> <li>Exits the current menu</li> </ul>

The most commonly used programming functions are available in the Quick Start menu. Additional programming options are accessed via the Main Menu.

**QUICK START**

Empty Pipe Detector	[E.P.Detect= ON]
Empty Pipe Threshold	[R max= Kohm XXXX]
Scaled Pulse Out 2 Volume	[Pls2=Gal XXX.XXX]
Pulse Out 2 Duration	[Tpls2=ms XXXX.X]
Analog Output 1 Full Scale Value	[A1S=Gal/m XXX.XX]
Quick Start	Quick Start = ON

NOTE: Please see complete FT-3100 Transmitter Programming Guide for additional guidelines and information.

**4.3 HELPFUL HINTS**

A step-by-step procedure and companion worksheet are located on the next two pages. Please read all installation instructions and these helpful hints carefully before proceeding with installation, start-up and commissioning.

1. ONICON flow meters are individually calibrated for a particular application. Be sure to verify the pipe size and location.
2. The electronic sensing system will not work in air. The pipe must be full for proper operation.
3. When measuring analog output signals, remember that currents (mA) must be measured in series, while voltages are measured in parallel. If the 4-20 mA signal is already connected to a control system, you must break the connection and measure the signal in series.
4. When measuring frequency outputs in hertz, take your multimeter out of "autorange mode" and manually set range for a voltage level above 15 VDC. This will prevent false readings when signal is not present.
5. Never connect power to analog or frequency output signal wires. ONICON FT-3100 Flow Meters are not "loop powered" devices.

**4.4 START-UP AND COMMISSIONING**

Please read the entire procedure carefully before proceeding. Wiring instructions are located on pages 25-28 of this manual. A worksheet for checking off the following steps and recording measured values is located on the next page.

1	Confirm flow meter location and adequate straight pipe run to achieve desired results.	Is the meter located in the correct location as required by the plans? Compare actual straight pipe upstream and downstream of the meter location to recommended distances identified in this manual.
2	Confirm control system programming.	Confirm that the control system input point is properly configured for the analog range (or scale factor) identified on the calibration certificate.
3	Verify wiring before connecting power.	Prior to connecting the power, verify that the wiring is correct as shown in this manual and/or the additional wiring diagram provided with the display or BTU meter. If in doubt, contact ONICON for assistance before proceeding further.
4	Verify that the input voltage available to power the meter is appropriate for the meter version.	Low Power, 24 VAC/DC, 50/60 Hz, 12 VA High Power, 120 - 240 VAC, 50/60 Hz, 12 VA
5	Connect power.	Wait approximately 45 seconds after power-on before proceeding further.

The following steps require flow in the pipe. Flow signal readings should be taken while holding the flow rate constant if possible. Otherwise, take the various output readings as quickly as possible.

6	<p>Measure and record analog or binary outputs.</p> <p>Current Output:</p> <p>Scaled Output:</p>	<p>Refer to flow meter wiring diagram for the various outputs available based on your particular flow meter model. Use the following formulas to calculate flow rate from measured analog signals:</p> $\text{GPM} = \frac{(\text{measured current in mA} - 4) \times \text{Full Scale Analog Flow Rate}}{16}$ <p>Each contact closure = unit volume identified as "Scale Factor" (measure and record time interval between contact closures)</p>
7	Compare various output signals to each other and to the flow rate displayed and to the control system.	Compare the flow rates calculated in STEP 6 to the flow rate indicated by the display and the control system. Refer to troubleshooting guide when readings are inconsistent.



**4.5 START-UP AND COMMISSIONING WORKSHEET**

Please read all installation instructions carefully prior to proceeding with these steps. Use the following worksheet for checking off the commissioning steps and recording measured values.

STEP	TEST/MEASUREMENT	S/N	S/N	S/N	S/N
1	Meter location:				
2	Control system programming:				
3	Signal connections verified:				
4	Supply voltage verified:				
5	Connect power:				

The following steps require flow in the pipe. Flow signal readings should be taken while holding the flow rate constant if possible. Otherwise, take the various output readings as quickly as possible.

	Analog or binary outputs				
	4-20 mA signal:	mA	mA	mA	mA
	Scaled output interval				
	Calculated flow rate	GPM	GPM	GPM	GPM
	Flow rates displayed on meter display	GPM	GPM	GPM	GPM
	Control system	GPM	GPM	GPM	GPM

**4.6 TROUBLESHOOTING GUIDE**

NOTE: Also refer to the START-UP AND COMMISSIONING GUIDE located on the preceding pages.

REPORTED PROBLEM	POSSIBLE SOLUTIONS
No signal	<ul style="list-style-type: none"> <li>Verify correct wiring to control system (See wiring diagram.)</li> <li>Check display for alarm messages. Verify that the pipe is full.</li> <li>Verify that the sensor body and transmitter are both connected to earth ground.</li> </ul>
Reading is too high or low	<ul style="list-style-type: none"> <li>Verify correct wiring to control system (see wiring diagram).</li> <li>Confirm that the output signals are consistent (frequency vs. analog, etc).</li> <li>Confirm that the control system is programmed for correct flow range or scale factor.</li> </ul>
Analog signal seems high or low and does not correspond to frequency output	<p>Check for ground loop or offset voltage:</p> <ul style="list-style-type: none"> <li>Verify that the sensor body and transmitter are both connected to earth ground.</li> <li>Disconnect analog signal input from control system and measure analog outputs directly from the flow meter.</li> <li>Re-connect signal input to control system and measure the analog signals again.</li> <li>Any difference between these readings indicates a potential ground loop or offset voltage.</li> <li>Please contact ONICON for further assistance.</li> </ul>
Control system displays flow rate, but no flow rate is indicated on the local display module or BTU meter.	<ul style="list-style-type: none"> <li>Verify that all of the wires from the flow meter are connected to the display module or BTU meter.</li> <li>The frequency output wire must be connected for any ONICON display or BTU meter.</li> </ul>

