



ONICON
Flow and Energy Measurement

F-1500

INSERTION TURBINE FLOW METER

ONICON's F-1500 Series Insertion Turbine Flow Meter is a flexible design that delivers accurate, reliable flow measurement in a wide variety of flow applications.



Saturated Steam • Superheated Steam • High Temperature Hot Water

F-1500

INSERTION TURBINE FLOW METER



Insertion turbine flow meters are ideal for use in larger steam lines where downsizing the line to improve flow measurement is not desirable. In these applications, the pitch of the turbine rotor is selected to match the expected steam flow velocity range in the pipe. This optimizes the operating range of the flow meter for the application.

DESCRIPTION

The ONICON F-1500 Series Insertion Turbine Flow Meter is a flexible design that delivers accurate, reliable flow measurement in a wide variety of steam flow applications. The integral temperature sensor and optional integral pressure sensor allow for direct mass flow measurement of steam and compensated flow measurement in compressed air and gases. A volumetric flow version of the meter is also available for liquid flow applications.

The F-1500 Series flow meters are provided with rotors that are optimized for low velocity steam and gas flow applications. Insertion meters are designed to be installed without system shutdown and are priced independent of line size, making them a very cost effective solution for retrofit projects.

APPLICATIONS

- Saturated steam
- Hot water to 450°F (232°C)

Applications with optional pressure sensor

- Superheated steam to 450°F (232°C)
- Compressed air

FEATURES

- Mass flow measurement from a single instrument
- Interchangeable rotors optimize flow meter performance over the expected flow range
- Integral 1,000 Ω platinum RTD for precise temperature measurement
- Available integral pressure transducer for accurate pressure readings at the meter location
- DC loop powered operation
- Power Over Ethernet (POE)
- Advanced signal processing algorithms ensure stable flow readings and reject noise
- Easy-to-install meter arrives fully programmed and ready to use
- Multi-analog output versions available
- HART® serial communication
- BACnet MS/TP, BACnet IP, MODBUS RTU or MODBUS TCP/IP serial communication available

CALIBRATION

Every ONICON flow meter is wet calibrated in a flow laboratory against standards that are directly traceable to NIST*. A certificate of calibration accompanies every meter.

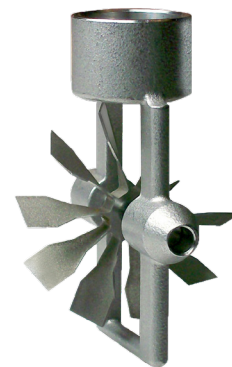

*NIST - National Institute of Standards and Technology

F-1500
INSERTION TURBINE FLOW METER



SPECIFICATIONS*

F-1500 TRANSMITTER		
PERFORMANCE	STEAM and GAS ACCURACY (Reynolds number $\geq 10,000$)	$\pm 1.5\%$ Volumetric flow rate $\pm 2\%$ Mass flow rate
	LIQUIDS ACCURACY	$\pm 1.25\%$ Volumetric flow rate $\pm 1.5\%$ Mass flow rate
	REPEATABILITY	$\pm 0.1\%$ Volumetric flow rate repeatability $\pm 2\%$ Mass flow rate repeatability
VELOCITY RANGE	MINIMUM VELOCITY	Liquid: 0.5 ft/s (0.15 m/s) Gas or steam: 3.5 to 12 ft/s (1 to 3.7 m/s) depending on rotor pitch
	MAXIMUM VELOCITY	Liquid: 30 ft/s (9 m/s) Gas or steam: 43 to 205 ft/s (13 to 62 m/s) depending on rotor pitch
OPERATING CONDITIONS	AMBIENT TEMPERATURE	-40°F to 140°F
	PROCESS TEMPERATURE	-67°F to 450°F
INPUT POWER	AVAILABLE OPTIONS	<ul style="list-style-type: none"> • Loop Power: 12-36 VDC, 25 mA max • External DC Power: 12-36 VDC, 300 mA max • External AC Power: 100-240 VAC, 50/60 Hz, 5W max • Power Over Ethernet (POE) or External 12-28 VDC
I/O SIGNAL	DC LOOP POWERED	One (1) 2-wire, 4-20 mA output One (1) 2-wire scaled pulse, 50 ms duration, 5-36 VDC @ 40 mA maximum HART serial communications
	EXTERNAL DC or EXTERNAL AC	Up to three (3) 2-wire, 4-20 mA outputs One (1) 2-wire scaled pulse output, 50 ms duration, 5-36 VDC @ 40 mA maximum Up to three (3) opto-coupled relay alarm outputs MODBUS RTU or BACnet MS/TP serial communications
	POWER OVER ETHERNET (POE) or EXTERNAL 12-28 VDC	Up to three (3) 2-wire, 4-20 mA outputs One (1) 2-wire scaled pulse output, 50 ms duration, 5-36 VDC @ 40 mA maximum Up to three (3) opto-coupled relay alarm outputs MODBUS TCP/IP or BACnet IP serial communications
ELECTRONICS ENCLOSURE	NEMA 4X (IP 66) epoxy painted aluminum	
	AVAILABLE OPTIONS	<ul style="list-style-type: none"> • Integral mount • Remote mount (standard cable length 50 ft, maximum 100 ft)
	DISPLAY	2-line, 16 character alphanumeric LCD with backlighting option.
APPROVALS	FM/FMC	Class I, Division 1, Group B, C, D Class II, Division 1, Group E, F, G Type 4X and IP66, Ta = -40 to 60°C
F-1500 FLOW SENSOR		
PERFORMANCE	SENSING METHOD	Axial mounted rotating turbine utilizing inductive sensing Integral 1,000 Ω platinum RTD provides instantaneous temperature Integral pressure transducer (optional) provides instantaneous pressure.
OPERATING CONDITIONS	MAXIMUM OPERATING PRESSURE	\leq Flange rating
	PRESSURE LOSS	Pressure loss varies with meter size and flow rate. Please contact ONICON for detailed information
FLOW SENSOR DESIGN	316L Stainless Steel	

* SPECIFICATIONS subject to change without notice.

FLOW METER OPERATING RANGES FOR SATURATED STEAM

	Pressure (psig)	5			15			50			75		
Sched 40 Steel Pipe Size	Density (lb/ft ³)	0.0491			0.0721			0.1496			0.2036		
	Rotor	R10	R25	R40	R10	R25	R40	R10	R25	R40	R10	R25	R40
lbs/hr													
3"	Minimum	90	36	25	109	44	31	158	65	45	185	76	52
	Maximum	1405	540	287	2073	797	424	4337	1672	890	5922	2284	1217
4"	Minimum	158	64	45	192	78	54	279	114	79	326	133	92
	Maximum	2464	948	504	3635	1399	745	7602	2932	1562	10378	4005	2135
6"	Minimum	373	152	105	453	185	128	657	268	186	768	314	218
	Maximum	5790	2230	1187	8539	3291	1753	17847	6891	3673	24355	9410	5018
8"	Minimum	660	270	187	802	328	228	1162	476	330	1359	556	386
	Maximum	10227	3942	2098	15078	5816	3098	31499	12170	6491	42977	16616	8865
10"	Minimum	1057	432	300	1284	526	365	1860	762	529	2175	891	619
	Maximum	16342	6302	3357	24089	9298	4955	50305	19447	10375	68622	26546	14169
12"	Minimum	1551	635	441	1870	766	532	2708	1110	771	3165	1298	902
	Maximum	23736	9162	4883	34976	13512	7205	72999	28244	15078	99557	38544	20585
14"	Minimum	1892	775	538	2299	942	654	3328	1365	948	3889	1596	1109
	Maximum	29115	11246	5997	42891	16581	8847	89476	34642	18502	122006	47266	25255
16"	Minimum	2536	1039	722	3081	1264	878	4459	1831	1273	5211	2141	1489
	Maximum	38897	15044	8029	57279	22170	11838	119399	46278	24736	162762	63121	33752

	Pressure (psig)	100			150			200			300		
Nominal Diameter in inches	Density (lb/ft ³)	0.2569			0.3627			0.4680			0.6791		
	Rotor	R10	R25	R40	R10	R25	R40	R10	R25	R40	R10	R25	R40
lbs/hr													
3"	Minimum	209	85	59	249	101	70	283	116	80	342	140	97
	Maximum	7490	2890	1540	10608	4097	2184	13719	5301	2827	19966	7721	4120
4"	Minimum	367	150	104	437	179	124	497	203	141	601	246	171
	Maximum	13123	5068	2702	18583	7181	3830	24028	9290	4957	34961	13528	7222
6"	Minimum	864	354	245	1030	421	293	1172	480	333	1415	580	403
	Maximum	30791	11902	6350	43586	16861	8999	56341	21807	11643	81946	31743	16958
8"	Minimum	1529	626	435	1821	746	518	2073	850	590	2503	1026	713
	Maximum	54325	21014	11216	76881	29761	15892	99362	38486	20558	144481	56008	29934
10"	Minimum	2447	1003	697	2914	1195	831	3316	1360	945	4004	1643	1142
	Maximum	86731	33568	17923	122718	47533	25391	158579	61458	32842	230539	89422	47810
12"	Minimum	3561	1461	1015	4240	1741	1210	4825	1981	1377	5824	2393	1664
	Maximum	125807	48732	26034	177963	68985	36871	229926	89178	47681	334180	129717	69392
14"	Minimum	4375	1796	1249	5210	2140	1488	5927	2435	1693	7154	2941	2045
	Maximum	154154	59750	31935	218021	84564	45218	281645	109300	58464	409278	158953	85066
16"	Minimum	5861	2409	1675	6977	2869	1996	7937	3265	2271	9578	3942	2743
	Maximum	205605	79772	42668	290706	112863	60393	375467	145841	78064	545477	212020	113540

FLOW METER OPERATING RANGE FOR WATER SERVICE

Water Minimum and Maximum Flow Rates							
Rate	Sched 40 Steel Pipe Size						
	2	3	6	8	12	16	24
GPM Min	5	12	54	109	247	386	877
GPM Max	314	691	2701	4678	10575	16524	37950

TYPICAL METER INSTALLATION

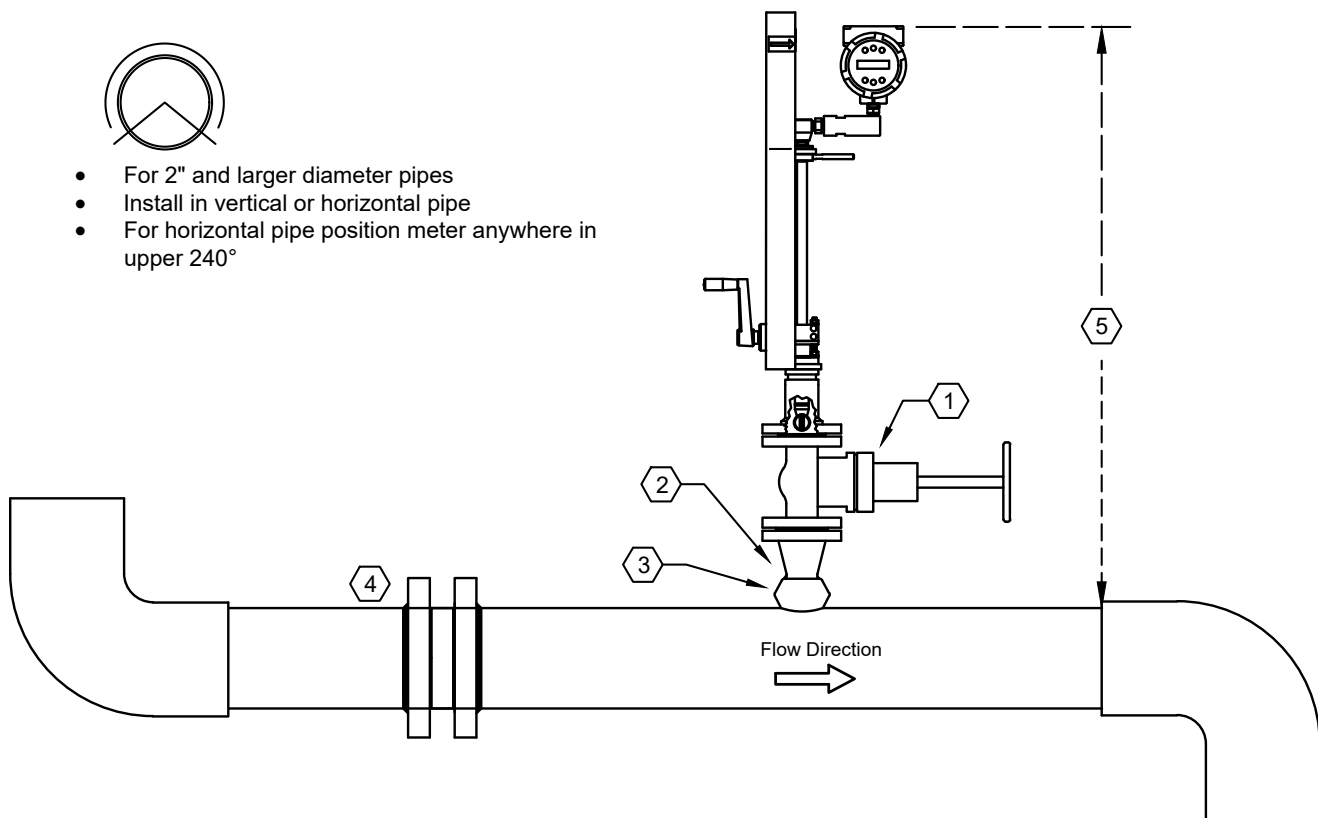

- For 2" and larger diameter pipes
- Install in vertical or horizontal pipe
- For horizontal pipe position meter anywhere in upper 240°

Note: Refer to the F-1500 IOM for detailed information about minimum upstream straight pipe run to first obstruction.

1. 2" flanged gate valve (full port)
2. Weld neck flange
3. 2" weld-on outlet
4. Flow straightener (if used)
5. Minimum downstream straight pipe run ≥ 5 diameters
6. 60" minimum clearance required for installation

METER ORDERING INFORMATION

Meter Model Number Coding = F-1500-CDEF-GHIJ

F-1500 = Industrial Insertion Turbine Flow Meter

C = Process Connection

- 2 = Packing gland with 2" NPT male threads and retractor - water only
- 4 = Packing gland with 2" ANSI Class 150 flange and retractor
- 5 = Packing gland with 2" ANSI Class 300 flange and retractor

D = Electronics Enclosure Mounting Configuration

- 1 = Integral mount, NEMA 4X enclosure
- 2 = Remote mount transmitter with 50' of cable
- 3 = Remote mount transmitter with 100' of cable

E = Temperature/Pressure Compensation

- 0 = Integral temperature compensation
- 2 = Integral temp and pressure compensation, 100 psia max
- 3 = Integral temp and pressure compensation, 300 psia max
- 4 = Integral temp and pressure compensation, 500 psia max

F = Rotor Selection

- 0 = Liquid
- 1 = R40 - Steam or gas
- 2 = R30 - Steam or gas
- 3 = R25 - Steam or gas
- 4 = R20 - Steam or gas
- 5 = R15 - Steam or gas
- 6 = R10 - Steam or gas

G = Input Power

- 0 = Loop power
- 1 = External 12-36 VDC
- 2 = External 100 - 240 VAC
- 3 = Power Over Ethernet (POE) or External 12-28 VDC

H = Output Signals

- 0 = Loop powered 4-20 mA and scaled pulse (only available for input power selection where G = 0)
- 1 = (1) 4-20mA, (1) scaled pulse, (1) alarm contact and MODBUS RTU (Requires G=1 or 2)
- 2 = (1) 4-20mA, (1) scaled pulse, (1) alarm contacts and BACnet MSTP (Requires G=1 or 2)
- 3 = (3) 4-20mA, (1) scaled pulse, (3) alarm contacts and MODBUS RTU (Requires G=1 or 2)
- 4 = (3) 4-20mA, (1) scaled pulse, (3) alarm contacts and BACnet MSTP (Requires G=1 or 2)
- 5 = (1) 4-20mA, (1) scaled pulse, (1) alarm contact and MODBUS TCP/IP (Requires G=3)
- 6 = (1) 4-20mA, (1) scaled pulse, (1) alarm contacts and BACnet IP (Requires G=3)
- 7 = (3) 4-20mA, (1) scaled pulse, (3) alarm contacts and MODBUS TCP/IP (Requires G=3)
- 8 = (3) 4-20mA, (1) scaled pulse, (3) alarm contacts and BACnet IP (Requires G=3)

I = Max Operating Temperature

- 0 = 450°F

J = Energy Meter Configuration

- 0 = None
- 1 = Gross energy
- 2 = Net energy

REMOTE TEMPERATURE SENSOR AND THERMOWELL INSTALLATION KIT

(Required for Net Energy Meter)

Model Number	Description
TSI-RKP-1461	4 wire 1000 OHM RTD Sensor, .25" x 2.8", 32 - 250°F temperature range with 10" leads
INSTL204S-TSI	Temperature sensor installation kit for pipe size range from 1.5"-8". Wetted materials are SS, for use in carbon steel piping systems

Note: Net energy meter requires one temperature sensor and one thermowell installation kit sized to pipe.

