

TECH NOTES

F-1100 and F-1200 Insertion Turbine Flow Meters



INSTALLATION AND REMOVAL INSTRUCTIONS

OVERVIEW

ONICON's F-1100 and F-1200 Insertion Turbine Flow Meters can be installed or removed without system shutdown. Installation and removal can be done by hand with up to 400 psi system pressure.

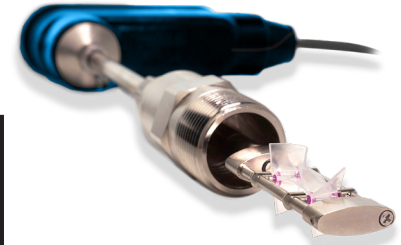

RECOMMENDED TOOLS

- Adjustable Open End Wrench
- Adjustable Pipe Wrench
- Flashlight
- Small Brass Bristle Brush
- Pipe Dope or Paste Type Thread Sealant
- Silicone Grease

The installation and removal procedures can be viewed on our YouTube channel.

[INSTALLATION](#)

[REMOVAL](#)

IMPORTANT NOTE

DO NOT use petroleum based lubricants (WD-40, machine oil, etc.) on the flow meter. Petroleum based lubricants will damage the flow meter's o-ring seals.

F-1000 SERIES DIAGRAM

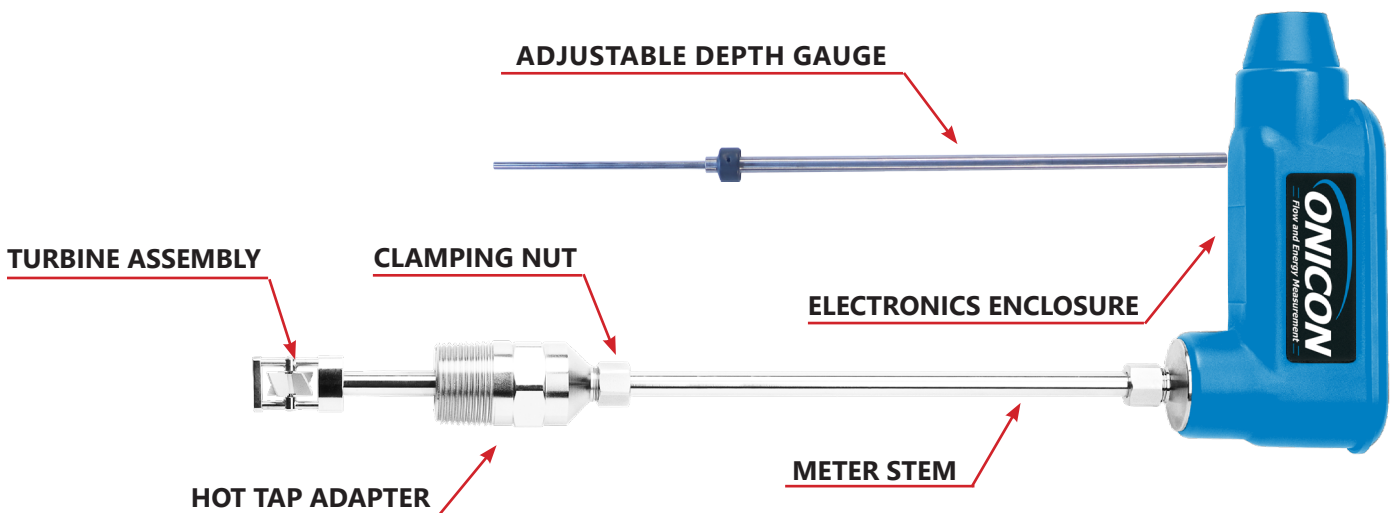

INSTALLATION PROCEDURE

1. Slide the flow meter hot tap adapter up the meter stem to expose the turbine assembly and inspect the turbine(s) to ensure debris is not restricting free rotation.
2. Slide the hot tap adapter back down to cover the turbine assembly.
3. Apply a thin coat of pipe dope thread sealant on the hot tap adapter threads. Avoid using an excess amount.
4. Inspect the inside of the ball valve to make sure that the threads are clean. Use a small brass bristle brush to clean the threads of excess debris or thread tape.
5. With the turbine assembly fully retracted, position the flow meter in line with the ball valve opening and carefully thread the hot tap adapter into the ball valve.

F-1100 and F-1200 Insertion Turbine Flow Meters INSTALLATION AND REMOVAL INSTRUCTIONS

INSTALLATION PROCEDURE (CONTINUED)

6. Keeping the turbine assembly fully retracted, use the wrench to tighten the hot tap adapter into the ball valve. DO NOT over-tighten, it is not necessary to apply excessive pressure as the thread sealant will prevent any leaks.
7. Once the hot tap adapter is tightened, open the ball valve.
8. Place the flow meter insertion gauge tip through any insulation to the pipe surface and with the clamping nut loose, gently push the flow meter down into the pipe until the other end of the gauge touches the underside of the electronics enclosure.
9. Align the flow meter to the flow direction in the pipe using the flow direction arrow on the side of the electronics enclosure.
10. Use the wrench to tighten the clamping nut, securing the meter in place.

IMPORTANT NOTE

DO NOT over-tighten the clamping nut.

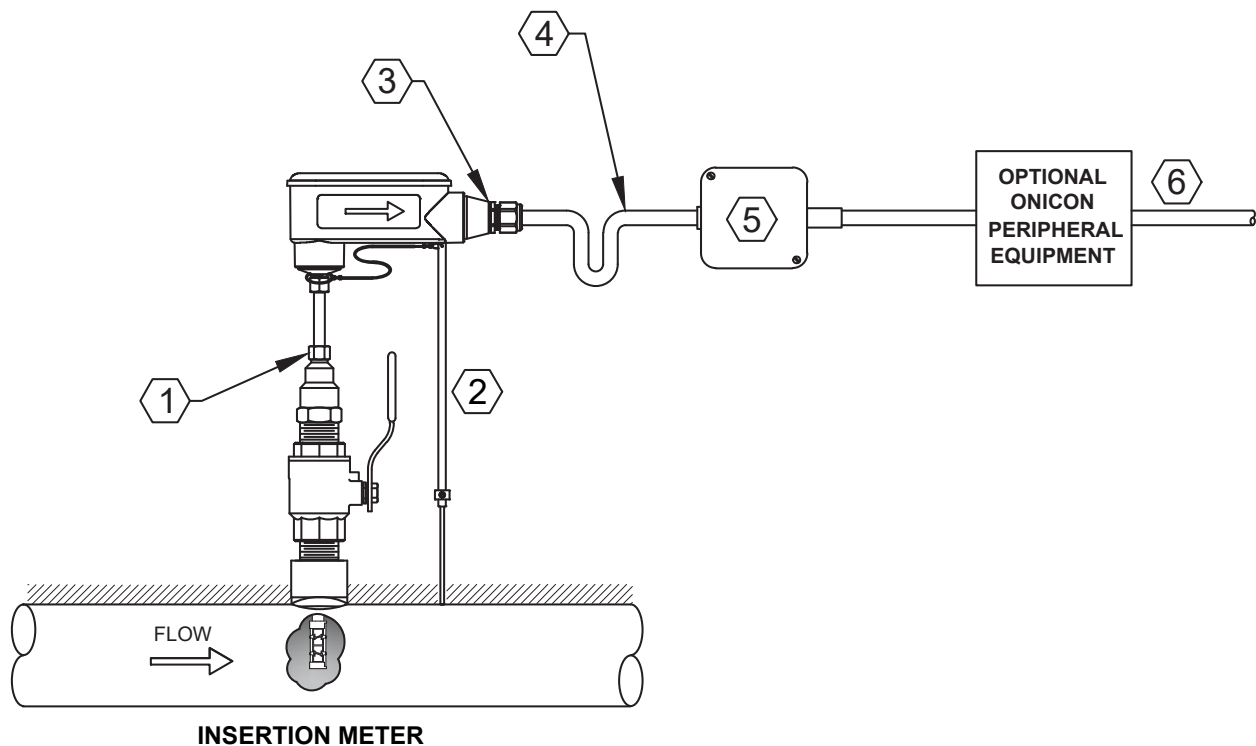

1. Clamping nut.
2. Adjustable depth gauge. Gauge length is based on flow meter model and pipe size.
3. 1/2" FNPT conduit connection.
4. Provide enough slack in flexible conduit connection, between flow meter enclosure and field junction box, allowing for flow meter removal.
5. Connect factory wires to field wires in appropriate junction box.
6. Flow meter output signals provided for connection to control system and ONICON peripheral equipment.

F-1100 and F-1200 Insertion Turbine Flow Meters INSTALLATION AND REMOVAL INSTRUCTIONS



REMOVAL PROCEDURE

CAUTION

Make sure you have secure footing and are in a comfortable position to work with the flow meter.

1. Place one hand on top of the meter electronics housing to hold it against the line pressure.

IMPORTANT NOTE

There will be force equal to 1/10th of the line pressure pushing up on the flow meter. Always place your hand on top of the flow meter electronics enclosure before loosening the clamping nut.

2. Using the wrench, slowly loosen the clamping nut and allow the pipe pressure to push the meter up out of the pipe. When fully retracted, the turbine assembly will hit a metal stop inside the hot tap adapter. Tighten the clamping nut.
 - 2a. If there is an irregular opening in the pipe, the turbine assembly may retract into the pipe wall. Push the meter down slightly, turn it 90° and allow the meter to retract again. The turbine assembly may contact the pipe wall preventing the meter from being fully retracted.
 - 2b. If there is buildup on the stem, it may be difficult to pull the meter up and out of the pipe. Apply a small amount of silicone grease to the stem above the clamping nut. Push the meter into the pipe 3" to lubricate the o-ring seal located in the hot tap adapter.

IMPORTANT NOTE

If the wiring and conduit restricts the ability to retract the meter fully, the cable may have been cut too short during the initial installation; the cable will need to be disconnected at the junction box.

DO NOT cut cable or try to disconnect at flow meter electronics enclosure. Wiring should only be discontinued at the remote junction.

3. Gently close the ball valve to isolate the line. If you feel any resistance when trying to close the ball valve, stop and open the ball valve again. Repeat steps 2, 2a and 2b.
4. Begin to unscrew the hot tap adapter from the ball valve.
 - 4a. If the flow meter hot tap adapter was overtightened during the installation, the ball valve may also turn when unscrewing the hot tap adapter. Use a pipe wrench to hold the ball valve in position until the flow meter hot tap adapter is loose enough to turn without turning the ball valve.

IMPORTANT NOTE

To prevent turbine damage, keep the flow meter fully retracted inside the hot tap adapter.

F-1100 and F-1200 Insertion Turbine Flow Meters

INSTALLATION AND REMOVAL INSTRUCTIONS

COMMON MISTAKES TO AVOID

- Closing the ball valve before the flow meter is fully retracted up into the hot tap adapter. This often crushes the turbine blades and damages the meter stem. In worse cases, the stem can be so badly bent that the flow meter cannot be removed without removing the complete ball valve assembly.
- Forcefully pushing the flow meter into the pipe may cause the turbine assembly to come in contact with the opposite pipe wall, causing damage to the assembly.
- During the removal process, once the ball valve is closed and there is no line pressure the flow meter can slide down into the ball valve. If this happens and the last thread is released, the flow meter can fall to one side, bending or damaging the turbine assembly.

IMPORTANT NOTE

A damaged turbine assembly can result in water leaking through the stem and into the electronics enclosure.

If you have any questions or need further assistance, please contact ONICON Technical Support at (727) 447-6140 or technicalsupport@onicon.com.

