

Flow Meter Site Selection General Guidelines

F-1100 & F-1200 Series Insertion Turbine Flow Meters

- Install in vertical or horizontal pipe

F-3500 Series Insertion Electromagnetic Flow Meters

- Install in vertical or horizontal pipe
- Standard Configuration: 3" & larger diameter pipes
- Small Pipe Configuration: 1¼ - 2½" diameter pipes

F-3500 Series Insertion Electromagnetic Flow Meters (Bi-directional)

- Acceptable to install in vertical pipe
- For 3" and larger diameter pipes

IMPORTANT NOTE
Always use the maximum available straight run. When more than the minimum required straight run is available place the meter such that the excess straight run is upstream of the meter location.

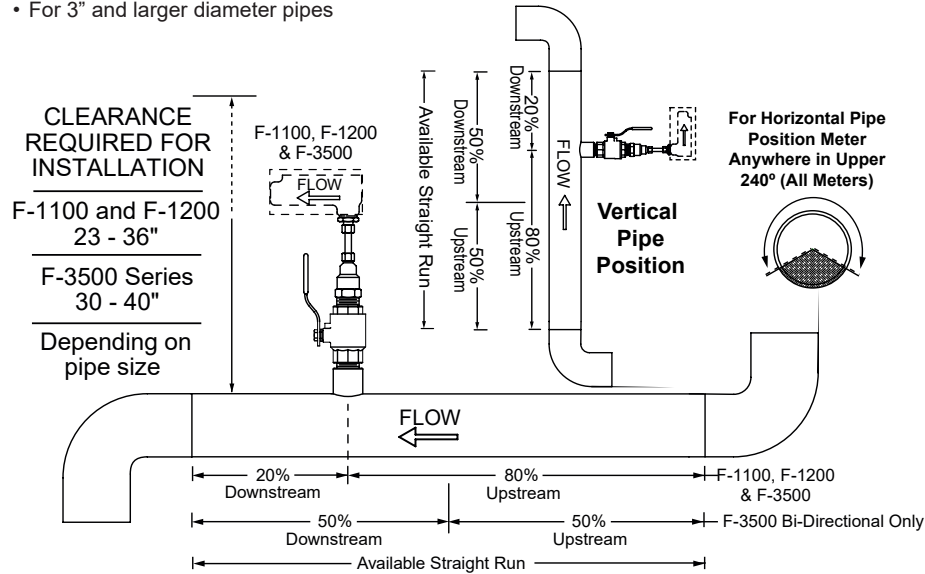

Evaluating Upstream Piping Conditions

- Better ↑
- Straight Pipe
 - Single Bend
 - Pipe Reduction or Enlargement
 - Outflowing Tees
- Worse ↓
- Multiple Bends in Same Plane
 - Multiple Bends Out of Plane
 - Inflowing Tees
 - Control Valves

How to determine the available straight pipe diameters:
For each application, locate the longest straight, unobstructed section of pipe (no bends, tees, valves, other insertion probes, size transitions). The longest straight pipe run in inches divided by nominal pipe size in inches equals "diameters of straight pipe." For closed loop applications, consider both the supply and return lines as possible locations.

Straight Run Requirements for Insertion Flow Meters

- For best results, install the flow meter in a straight run of pipe, free of bends, tees, valves, transitions, and obstructions.
- Straight run requirements vary based on the nature of the upstream obstruction. Longer straight runs may be required in applications where the meter is placed downstream from devices which cause unusual flow profile disruption or swirl, for example, modulating valves or two elbows in close proximity and out of plane, etc. Please note that depending upon specific location details, more or less straight run may be required to produce a satisfactory flow profile.

Meters	Upstream	Downstream
F-1100	20D	5D
F-1200	10D	5D
F-3500	10D	5D
F-3500 Bi-Directional	10D	10D

Installation Hardware Instructions

Dry Tap Installation Kit for Welded Steel Pipe

For F-1000 Series, F-3500 Series Insertion Flow Meters



For Use With Kits: INSTL0001-FMD, INSTL01DW-FMD, INSTL0005-FMD, INSTL0018-FMD

This kit must be installed prior to filling the system, or into a section of pipe that is isolated from pressure and flow. Once installed, this kit allows for insertion and removal of the flow meter without a system shutdown.

Directions:

1. Identify an appropriate location for the flow meter.
2. Weld the branch outlet onto the pipe.
3. Drill a 1" (minimum) access hole in the pipe, centered in the branch outlet.
4. Install the close nipple and ball valve as shown below. Use a paste type thread sealant or use Teflon® tape. **DO NOT** use Teflon® tape for F-1100 & F-1200 Series.
5. Flush and fill the system prior to installing the meter.

IMPORTANT NOTE
ONICON insertion flow meters are precision measuring devices that must be installed according to the instructions contained in this document in order to maintain their accuracy and reliability. Failure to follow these instructions will result in erratic operation and reduced accuracy.

NOTE: Before installing the flow meter, read the entire installation manual.

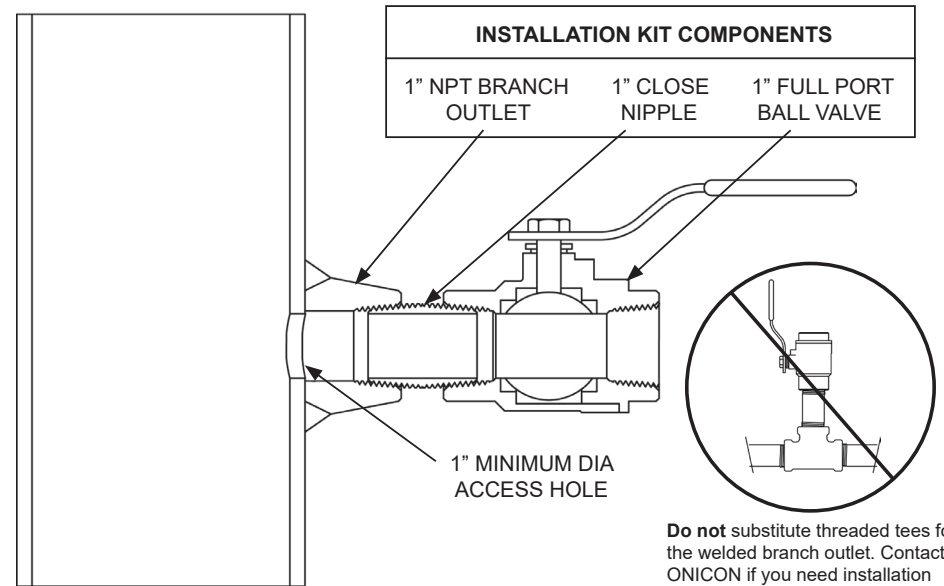

Dry Tap Installation Kit for 1¼ - 2½" Threaded Pipe
 For F-1000 Series & F-3500 Series Insertion Flow Meters

For Use With Kits: INSTL0007-FMD, INSTL0008-FMD

This kit must be installed prior to filling the system, or into a section of pipe that is isolated from pressure and flow. Once installed, this kit allows for insertion and removal of the flow meter without a system shutdown.

Directions:

1. Identify an appropriate location for the flow meter.
2. Install the threaded pipe nipple, close nipple and ball valve as shown below. Use a paste type thread sealant. **DO NOT** use Teflon® tape
3. Flush and fill the system prior to installing the meter.

NOTE: Before installing the flow meter, read the entire installation manual.

IMPORTANT NOTE

ONICON insertion flow meters are precision measuring devices that must be installed according to the instructions contained in this document in order to maintain their accuracy and reliability. Failure to follow these instructions will result in erratic operation and reduced accuracy.

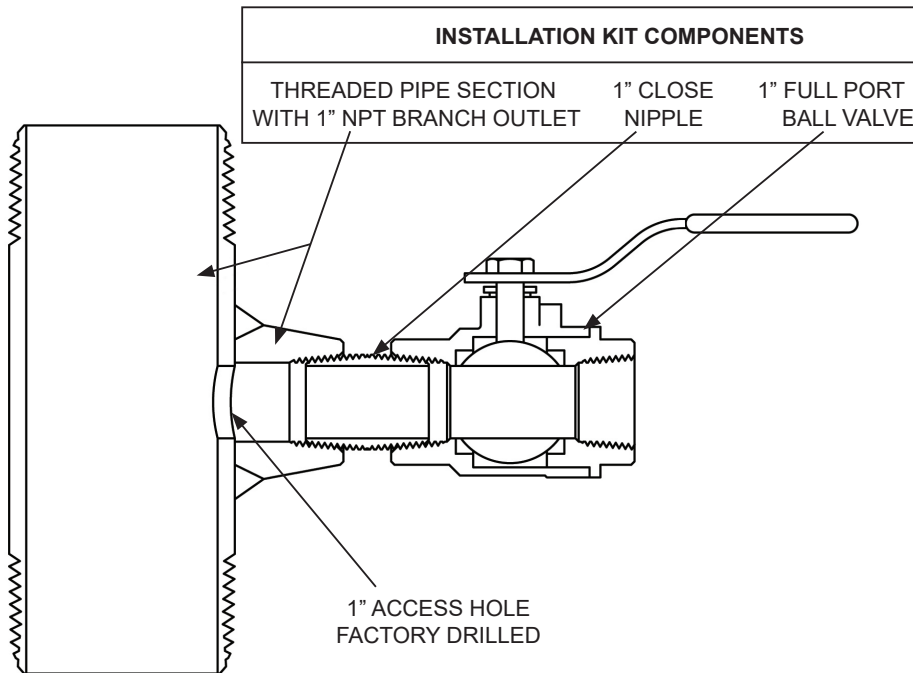

Dry Tap Installation Kit for Copper Tube (Components Comply with NSF61)
 For F-1000 & F-3500 Series Insertion Flow Meters

For Use With Kits: INSTL0003-FMD, INSTL0004-FMD, INSTL0009-FMD

This kit must be installed prior to filling the system, or into a section of pipe that is isolated from pressure and flow. Once installed, this kit allows for insertion and removal of the flow meter without a system shutdown.

Directions:

1. Identify an appropriate location for the flow meter.
2. Solder or braze the copper tee and adapter provided.
3. Install the ball valve as shown below. Use a paste type thread sealant or use Teflon® tape. **DO NOT** use Teflon® tape for F-1100 & F-1200 Series.
4. Flush and fill the system prior to installing the meter.

NOTE: Before installing the flow meter, read the entire installation manual.

IMPORTANT NOTE

ONICON insertion flow meters are precision measuring devices that must be installed according to the instructions contained in this document in order to maintain their accuracy and reliability. Failure to follow these instructions will result in erratic operation and reduced accuracy.

