



**Model D-1401 & D-1402 Portable Metering System
Installation and Operation Guide**



Safety Information

Throughout this manual text that involves safety related information, or information critical to the proper operation of the product will be identified in the following manner.



WARNING

Messages identified as "Warning" contain information regarding the personal safety of individuals involved in the installation, operation or service of this product.



CAUTION

Messages identified as "Caution" contain information regarding potential damage to the product or other ancillary products.



IMPORTANT NOTE

Messages identified as "Important Note" contain information critical to the proper operation of the meter.

Disclaimer

The information contained in this manual has been carefully prepared and checked for accuracy. ONICON assumes no liability for damages that might occur as a result of any errors or omissions in this manual.

Service requirements

This product contains a limited number of user serviceable parts. Only qualified personnel should install or service this product. Please do not hesitate to contact ONICON for assistance in the unlikely event that this product requires service.

TABLE OF CONTENTS

1.0 INTRODUCTION4

 1.1 Purpose of this Guide..... 4

 1.2 System Description4

 1.3 System Components..... 5

2.0 SYSTEM OPERATION AND SET-UP 6

 2.1 System Operation..... 6

 2.2 Initial System Set-up.....6

 2.3 Basic Flow Measurement.....7

 2.4 Flow Profiling Measurement.....7

 2.5 System Storage and Maintenance Recommendations.....8

 2.6 Flow Meter Information.....9

3.0 INSTALLATION, REMOVAL AND ADJUSTMENT 10

 3.1 Site Selection10

 3.2 Mechanical Installation11

 3.3 Insertion of the Meter13

 3.4 Removal of the Meter.....14

CONDITIONS OF SALE.....16

SECTION 1.0 INTRODUCTION

1.1 PURPOSE OF THIS GUIDE

The purpose of this guide is to provide installation procedures and basic operating and servicing instructions for the ONICON Model D-1401 and D-1402 Portable Metering System.

1.2 SYSTEM DESCRIPTION

The D-1401 and D-1402 Portable Metering Systems are designed to measure the flow rate of conductive liquids in multiple pipe sizes. They can also be used to perform flow profiling for analysis of flow measurement problems.

The D-1401 Portable Metering System includes a F-1100 single turbine flow meter and can be used to measure 1.25 inch and larger pipe sizes.

The D-1402 Portable Metering System includes a F-1200 dual turbine flow meter and can be used to measure 2.5 inch and larger pipe sizes.

The flow meter portion of the system is typically inserted into a filled and pressurized pipe via an existing one inch minimum diameter full port ball valve. For pipes that



can be easily drained before and after measurement, the flow meter can be inserted into a one inch minimum diameter outlet that can accept a one inch NPT male threaded adaptor. For filled and pressurized pipes without installed full port valves, wet tapping installation hardware kits are available from Onicon.

The display module includes an LCD display, control switches and cable. A single 9-volt alkaline battery, located in the display module battery compartment, powers the complete system, including the flow meter.

1.3 SYSTEM COMPONENTS

The D-1401 Portable Metering System contains the following components:

- Model F-1100 Insertion Turbine Flow Meter
- Model D-1401 battery powered hand-held display
- Carrying case
- Owner's manual
- Laminated conversion chart. (* Serialized for the specific F-1100 flow meter *)

The D-1402 Portable Metering System contains the following components:

- Model F-1200 Insertion Turbine Flow Meter
- Model D-1402 battery powered hand-held display
- Carrying case
- Owner's manual
- Laminated conversion chart. (* Serialized for the specific F-1200 flow meter *)

SECTION 2.0 SYSTEM OPERATION AND SET-UP

2.1 SYSTEM OPERATION

The D-1401 and D-1402 Display Module LCD display shows the flow rate as a number representing the frequency output signal, in Hertz, from the flow meter.

The D-1401 Display Module shows the frequency output signal of the single turbine from the F-1100.

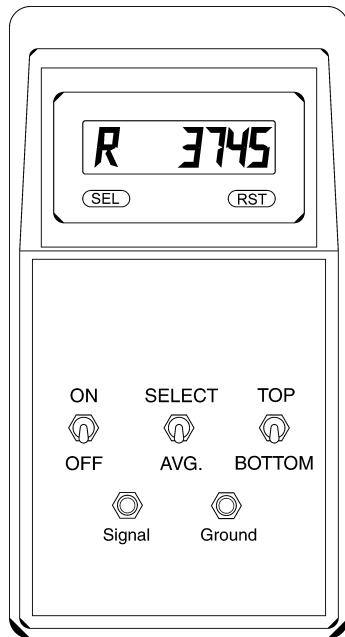

The D-1402 Display Module shows the averaged output from both turbines. This system also has the capability of displaying the individual output from the top or bottom turbine by using the selection switches on the Display Module.

This frequency output is then converted to gallons per minute for the pipe size being measured via the laminated conversion chart included with the system.

Please contact Onicon to obtain conversion factors for any pipe sizes not listed on the chart, or if you require a flow rate unit of measure other than gallons or liters.

2.2 INITIAL SYSTEM SET-UP

1. Insert the flow meter into the pipe to be measured. (See manual section entitled "Flow Meter Information" for specific information on installation procedures and recommended insertion depths.)
2. Plug the Display module cable connector into the connector on the flow meter output cable.
3. Turn the Display module power switch to the "ON" position and verify that a number appears on the LCD display.

2.3 BASIC FLOW MEASUREMENT

1. Turn the power switch (left) to “**ON**” position.
2. Set the middle switch to “**AVG**” and allow 45 seconds for the flow meter circuitry to stabilize.
3. Record the average reading in Hz on the display and refer to the laminated conversion chart to calculate the flow rate. Please note that the frequency number displayed may vary rapidly (by as much as 10-15%) as a result of the actual flow conditions in the pipe.
4. Locate the pipe size being measured on the laminated conversion chart and determine the “Z Factor” for gallons per minute (or liters per minute) for that pipe size.
5. Then multiply the Z factor by the average reading in Hz from step 3 to obtain the flow rate in gallons per minute.

2.4 FLOW PROFILING MEASUREMENT

D-1401 / D-1402 Systems:

Significant information about the nature of flow across the entire pipe diameter can be obtained by taking flow measurements at incremental insertion depths.

Depending on the pipe size to be measured, determine an appropriate measurement increment that will provide the required information. (For example: when measuring the flow profile of an 8-inch pipe, measurements may be made at 1 inch increments to provide the desired profile.)

With the flow meter properly inserted in the pipe, loosen the hot tap adaptor lock nut and push the meter into the pipe until the end of the meter touches the far pipe wall. Using this as a starting point, pull the meter back out by the desired increment of measurement and measure the flow rate. Repeat this process until readings have been made across the entire interior diameter of the pipe.

In large pipes where the flow meter is not long enough to touch the far pipe wall, measurements can be made using the near pipe wall as a starting point. Push the flow meter into the pipe just until a flow reading is obtained on the display. (For the D-1402 systems, the top turbine output can be observed to see when it clears the pipe wall and begins to spin.) Beginning at that point, start making measurements at the desired incremental insertion depths.

D-1402 System Only:

When using a D-1402 system, the individual top and bottom turbine frequencies can be observed as a reference to the amount of rotational swirl that is present at each insertion depth measurement point.

To utilize this function, set the middle switch to “**SELECT**”. The right switch can then be toggled between “**TOP**” and “**BOTTOM**” to display the individual turbine frequencies.

A stable, uniform flow velocity at the measurement depth will be indicated by having the same or very close (+/- 10%) to the same frequency reading on both the top and bottom turbine.

A significant difference between the top and bottom turbine frequency numbers will indicate the presence of flow turbulence and swirl at the measurement depth. The top and bottom turbines rotate in opposite directions. Turbulence and swirl will either increase or decrease the speed of rotation of one of the turbines and will have the opposite effect on the other turbine.

2.5 SYSTEM STORAGE AND MAINTENANCE RECOMMENDATION

1. Always store the system in its carrying case when not in use.
2. Before long-term storage of the system, blow all excess water from the flow meter turbine assembly and wipe the flow meter stem assembly dry with a clean cloth. **Do not put any lubricants on the turbine assembly.** Oil based lubricants will damage the flow meter’s o-ring seals.
3. If storing the system for long periods of time, remove the 9-volt battery from the Display Module and store it separately.
4. The flow meter’s hot tap adapter should be pushed completely down over the turbine assembly and locked so that the turbines are protected when moving the system to a new location or when storing the system.
5. The flow meter turbines, bearings and shafts can be cleaned using a 30 percent white vinegar to 70 percent tap water solution. An old toothbrush can be used to lightly brush around the bearings. Rinse with clean water and blow off excess water before storing.

2.6 FLOW METER INFORMATION

ONICON's D-1401 / D-1402 Insertion Turbine Flow Meter measures the velocity of flowing liquids by counting the frequency at which the blades of a rotating turbine pass a fixed electrode. Circuitry within the flow meter electronics enclosure then converts the rotational rate to a frequency output.

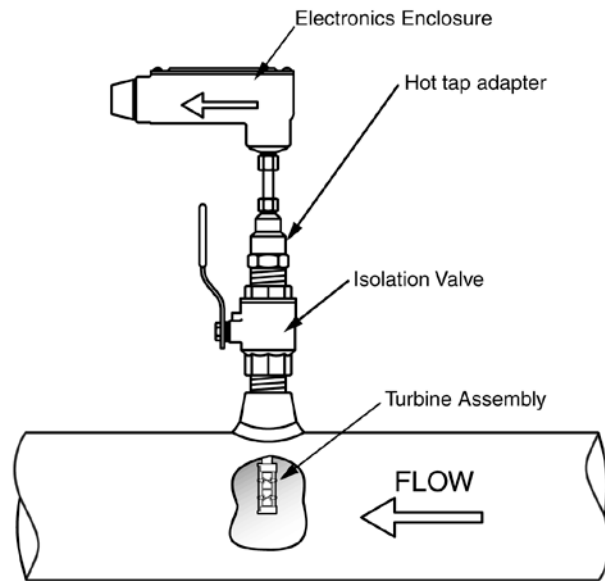

SECTION 3.0 INSTALLATION, REMOVAL & ADJUSTMENT

CAUTION

Insertion Flow Meters may often be installed in pipes which are under high pressure. Accidents with these systems can cause serious injury or death. Only persons experienced with high pressure systems and related knowledge in the heating, cooling and fluid metering fields should attempt to install adjust or remove the flow meter. Refer to the installation drawings before performing any work on these meters.



3.1 SITE SELECTION

The clearance required for installation is typically 30-36" from the pipe wall to the nearest obstruction above the valve assembly. This clearance dimension will increase with large diameter pipes.

The environment should be free of corrosive liquids/fumes, temperature extremes and heavy vibration. The following diagrams should be used as a guide to the proper location for installing the meter.

MECHANICAL INSTALLATION LAYOUT Series F-1100 Single Turbine Flow Meters

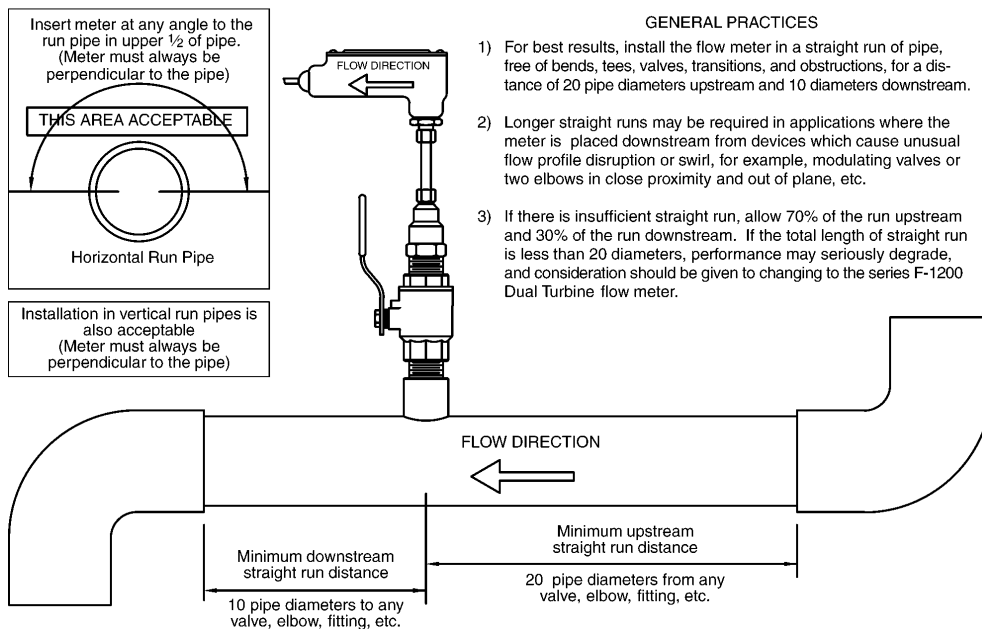

MECHANICAL INSTALLATION LAYOUT
Series F-1200 Dual Turbine Flow Meters

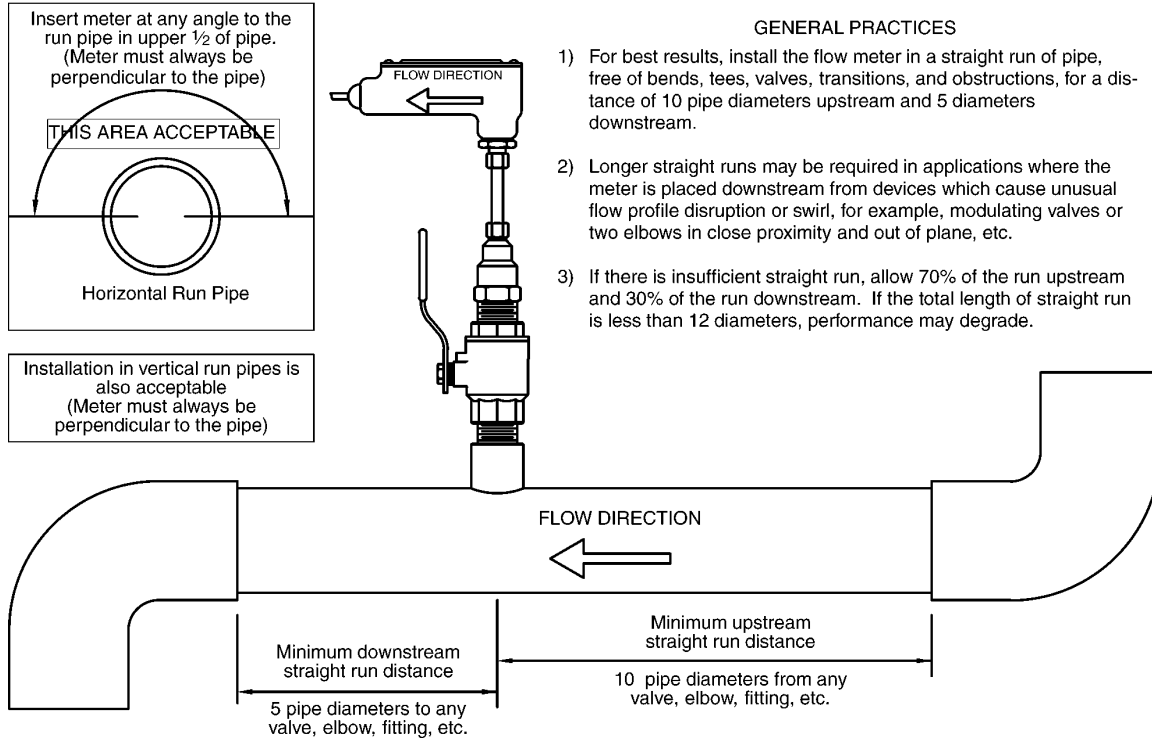

GENERAL PRACTICES

- 1) For best results, install the flow meter in a straight run of pipe, free of bends, tees, valves, transitions, and obstructions, for a distance of 10 pipe diameters upstream and 5 diameters downstream.
- 2) Longer straight runs may be required in applications where the meter is placed downstream from devices which cause unusual flow profile disruption or swirl, for example, modulating valves or two elbows in close proximity and out of plane, etc.
- 3) If there is insufficient straight run, allow 70% of the run upstream and 30% of the run downstream. If the total length of straight run is less than 12 diameters, performance may degrade.

3.2 MECHANICAL INSTALLATION

To take advantage of the ONICON Flow Meter's built-in Hot Tap feature, it must be installed through an isolation valve. The location must allow sufficient overhead clearance for meter removal.

IMPORTANT! A full 1" opening is required to clear the turbine assembly. Make sure that your valves and fittings are full port and at least 1" in actual internal diameter. Also, note that an oversized access hole can cause undesirable turbulence.

Typical ONICON Installation Hardware Kits:

ONICON's INSTL1 *Standard Installation Hardware* kit for black iron pipe is for use in a drained, non-pressurized system. The access hole is drilled (1" minimum) prior to installation of the 1" NPT branch outlet, close nipple and full port ball valve. Once the isolation valve is installed, the piping system can be flushed and pressurized. The flow meter may now be inserted or removed by hand without having to drain the system. Please read all instructions before proceeding with meter insertion.

ONICON's INSTL2 *Hot Tap Installation Hardware* kit for black iron pipe offers an alternative installation when it is not practical to drain or relieve the pressure in the system. In this case, a 1¼" branch outlet, close nipple and 1¼" full port ball valve are installed first. Then, a hot tap drilling apparatus can be used to drill a 1" diameter hole through the valve, without shutting down or draining the pipe.

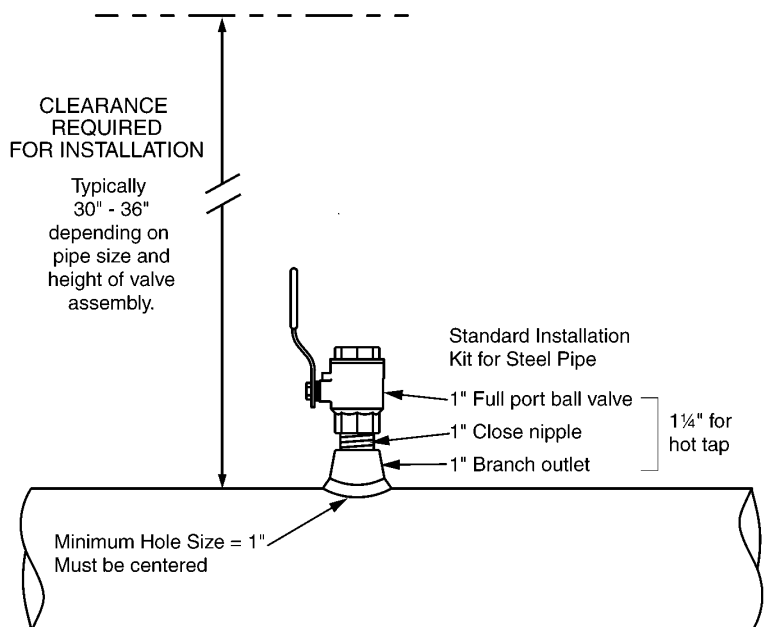

(See Appendix A for List of Available Onicon Installation Hardware Kits for other types of pipe materials and applications.)

After fitting the necessary plumbing hardware, flush the entire system so that it is free of flux, solder and slag. Prepare to install the flow meter by loosening the clamping nut and withdrawing the turbine assembly fully into the hot tap adapter. Next, thread the adapter on to the ball valve using a paste type thread sealant. Do not use Teflon tape because torn strands of the tape may wind around the turbine, slowing down or even stopping the turbine.

Check the installation for leaks by slightly opening the ball valve. An 'O' ring in the hot tap adapter seals the meter stem against leakage. If there are any leaks around the clamping nut or stem, **DO NOT ATTEMPT TO STOP THE LEAKAGE BY OVERTIGHTENING THE CLAMPING NUT.** Damage to this nut or the clamping ring under the nut may prevent the assembly from properly holding the meter in the pipe. The clamping nut is not part of the sealing mechanism. Any leaks in this area indicate that the 'O' ring is not sealing properly and you must contact the factory for assistance.

3.3 INSERTION OF THE METER

CAUTION

SYSTEM MAY BE UNDER HIGH PRESSURE. When adjusting the meter position or removing it, be sure to hold the electronics enclosure firmly by hand before **SLOWLY** loosening the positioning clamping nut. Failure to do this will allow the pressure to suddenly and rapidly force the meter from the pipe causing serious injury. The meter could also be damaged or break apart causing a break in the water seal with the resultant loss of large amounts of water. The hand effort required to hold the meter will be 0.11 times the pipe pressure.

Begin by calculating the effort that will be required to hold the meter. Establish adequate footing for this task, taking extra caution when working from a ladder or platform. Use the following formula:

$E = 0.11 \times P$ Where: **E** = effort in pounds

P = system pressure in pounds per square inch

Example: In a 300 PSI system, 33 pounds of effort is required to insert the meter into the pipe.

CAUTION

Do not release the flow meter until you have tightened the position clamping nut enough to hold the flow meter in the desired position. This will require less torque than you might think, so be careful not to overtighten it and risk damaging the adapter, nut or stem.

3.4 REMOVAL OF THE METER

CAUTION

Remember, the meter may be under high pressure, and while removal of the meter is basically the reverse of the insertion procedure detailed above, care must be taken to ensure that the meter is supported against the pipe pressure before the position clamping nut is loosened. Failure to do this will allow the pressure to suddenly and rapidly force the meter from the pipe causing serious injury.

CAUTION

Prior to removal of the meter, make sure that you are standing on a secure platform and have both hands available to manipulate the flow meter.

First support the flow meter against the pipe pressure by holding the electronics enclosure firmly in hand BEFORE loosening the position clamping nut. The effort which will be required is the same as that required for insertion of the meter and should be calculated according to the formula in the prior section covering insertion of the meter. This effort will be 0.11 times the pipe pressure. **If your footing is not secure, or if your ability to hold the meter limited for any reason, DO NOT loosen the clamping nut.**

SLOWLY loosen the position clamping nut and **carefully and slowly** allow the pressure to force the meter out of the pipe.

This is not at all difficult, but you must not let go of the meter until it is fully withdrawn into the hot tap adapter. After the meter is completely withdrawn, you may close the isolation ball valve.

The main cause of damage to meters comes from accidentally closing the valve on the turbine assembly. To avoid this, gently rotate the meter by twisting the electronics enclosure back and forth (twist the stem, do not bend it) while you slowly close the valve. If the valve touches any part of the meter, you will feel it as you are twisting the meter. If the valve touches anything, it means the meter is not fully withdrawn. Usually a gentle twisting motion while withdrawing the meter will clear any obstruction and permit the meter to withdraw completely. (Excessive build-up on the stem may require the hot tap 'O' ring to be lubricated with silicone.)

After the valve is completely closed, you can safely unscrew the hot tap adapter from the valve. Partially unscrew the adapter and allow pressure to vent from the hot tap adapter. There will be very little water in the hot tap adapter; however, a small bucket or pan should be held under the valve to catch any spilled water.

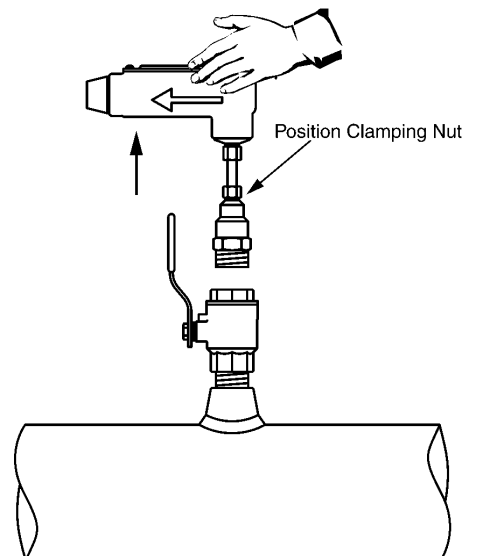



CAUTION

In hot water systems, even a small amount of water can cause serious personal injury. Use extra caution when working with hot water meters.

CONDITIONS OF SALE

1. **ACCEPTANCE:** The following Conditions of Sale apply to all sales of ONICON's products. These provisions shall apply even if ONICON fails to object to provisions appearing on, incorporated by, referenced in, or attached to Buyer's purchase order form. Buyer's acceptance of delivery of ONICON's products constitutes its acceptance of these Conditions of Sale.

2. **DELIVERY AND TITLE:** All product shipments are F.O.B. shipping point and title passes to the Buyer at the time ONICON delivers the merchandise to the carrier. Risk of loss or damage to the product passes to the Buyer at the time ONICON delivers the product to the carrier. The Buyer immediately upon receipt should inspect all shipments, and should there be any evidence of damage or loss in transit, Buyer must file claims or tracers upon carrier. ONICON will assist in tracing shipments upon request.

3. **LIMITED WARRANTY:** ONICON warrants that for a period of two (2) years following the date of original shipment of an ONICON product: (i) the product will conform to ONICON's standard written specifications applicable to such product in effect on the date of Buyer's order, or as modified by ONICON's quotation or Buyer's purchase order accepted by ONICON, (ii) the product will be free from defects in workmanship, and (iii) that ONICON has title to the product prior to shipment to the Buyer; provided, however, that the warranties provided herein shall be void and may not apply in the event Buyer misuses or damages a product, including, but not limited to, any use by the Buyer of a product for an application other than one of a type approved by ONICON. ONICON's sole liability and Buyer's sole remedy for any breach of the foregoing warranty is for ONICON to repair or replace, at ONICON's option, any defective product that is returned to ONICON during the warranty period. EXCEPT AS MAY BE SPECIFICALLY AGREED BY ONICON IN WRITING IN RELATION TO EACH SALE, NO OTHER WARRANTIES SHALL APPLY, WHETHER EXPRESSED, IMPLIED OR STATUTORY, AND THERE SHALL BE NO IMPLIED WARRANTIES OF MERCHANTABILITY AND FITNESS FOR A PARTICULAR PURPOSE.

4. **REMEDIES:** ONICON's OBLIGATION UNDER THE FOREGOING WARRANTIES IS LIMITED SOLELY TO REPAIR OR REPLACEMENT, AT ONICON'S OPTION, OF DEFECTIVE OR NONCONFORMING PRODUCTS. ONICON SHALL NOT BE LIABLE FOR CONSEQUENTIAL, INDIRECT, PUNITIVE, INCIDENTAL, OR SPECIAL DAMAGES WHETHER FOUND ON CONTRACT, TORT OR ANY OTHER THEORY OF LAW. No products shall be returned to ONICON without its prior consent and transportation and insurance costs shall be prepaid. Any repair or replacement of ONICON's products under the foregoing warranty will be at no charge to the Buyer provided such repair is done at the ONICON factory or authorized service center. ONICON products that are repaired or replaced under this warranty will be returned to Buyer via the same method of shipment used to return the product to ONICON. Repair or replacement of ONICON products is conditioned upon ONICON's acknowledgement of any alleged defect or nonconformance during the warranty period and issuance of a Return Authorization number. All product returns must reference the Return Authorization number on the outside of the shipping carton and on any paperwork referencing the return.

5. **PRICES AND PAYMENT TERMS:** The prices set forth in the most recent quote or acknowledgement as applicable, supersede all previous prices or quotations. All quotations are subject to change or withdrawal without notice except as may be specifically noted on the face of the quotation. The prices shown do not include sales, excise or government charges payable by ONICON to Federal, State, or local authority. Any such tax or charge now or hereafter imposed upon the sale or shipment of the products under this contract will be added to the purchase price. Buyer agrees to reimburse ONICON for such tax or charge or provide ONICON with an acceptable exemption certificate. Payment of invoices will be due 30 days from the date of shipment of the products contained therein. In the event that payment of an invoice is not received by the invoice due date, ONICON will assess a late fee not to exceed 1.5% per month or 18% per year, or the maximum allowable by law whichever is lower.

6. **CANCELLATION:** Buyer may cancel its order, or any part of it, by sending written notice of cancellation to ONICON and paying a reasonable cancellation fee as determined by ONICON. The reasonable cancellation fee will reflect, among other factors, the expenses already incurred and commitments made by ONICON, sales and administrative costs and profit as determined by ONICON. If Buyer received a reduced price based on the quantity of products ordered, but has not purchased the applicable quantity at the time of cancellation, Buyer will pay the price it would have paid had ONICON's sale price been based on the quantity actually purchased.

7. **CHANGES:** If Buyer makes any changes in its drawings, designs, or specifications applicable in any contract with ONICON that cause an increase or decrease in the cost of performance of the contract, or if such changes result in rework or obsolescence, an equitable adjustment shall be made to the contract. Such changes are subject to ONICON's prior written consent.

8. **EXCUSABLE DELAY:** ONICON shall under no circumstance be responsible for failure to fill any order or orders when due to: fires, floods, riots, strikes, freight embargoes or transportation delays, shortage of labor, inability to secure fuel, material supplies, or power at current price or on account of shortages thereof, acts of God or of the public enemy, any existing or future laws or acts of the Federal or State Government (including specifically, but not exclusively, and orders, rules or regulations issued by any official or agency of any such government) affecting the conduct of ONICON's business with which ONICON in its judgment and discretion deems it advisable to comply as a legal or patriotic duty, or due to any cause beyond ONICON's reasonable control.

9. **PATENTS:** ONICON shall defend all suits or proceedings brought against Buyer or its customers arising from claimed infringements of any patent, trademark, service mark or copyright for any product furnished by ONICON and shall indemnify it against all costs, fees, and damages on the condition Buyer promptly notifies ONICON in writing and provides information and assistance to enable ONICON to conduct the defense, provided that ONICON shall have no such obligation in case of infringement resulting from ONICON's conformance to special requirements of Buyer. If ONICON is not able to settle any such suit or proceeding on acceptable terms, ONICON may, at its option, require return of the infringing product and refund the purchase price to Buyer less a reasonable allowance for depreciation or use.

10. **FAIR LABOR STANDARDS ACT:** ONICON represents that all products delivered under this contract are furnished in accordance with the applicable provisions of the Fair Labor Standards Act as amended.

11. **APPLICABLE LAW:** This document and any resulting contract shall be governed by and construed in accordance with the laws of the State of Florida. The courts of the State of Florida and the federal courts located in Florida shall have jurisdiction and venue with respect to litigation to this contract. In the event of litigation, the prevailing party shall be entitled to recover attorney's fees and costs from the non-prevailing party, including appellate attorney's fees.

12. **MODIFICATIONS:** These Conditions of Sale along with the prices, quantities delivery schedules and other provisions and instructions in applicable quotations by shall constitute the entire agreement between ONICON and Buyer pertaining to any resulting contract. They can be modified only in writing.