

D-100 Flow Display LonWorks Network Interface Installation Guide



TABLE OF CONTENTS

1.0	INTRODUCTION	5
1.1	PURPOSE OF THIS GUIDE	5
1.2	TYPICAL D-100 FLOW DISPLAY	5
1.3	SPECIFICATIONS	5
1.4	NETWORK SIGNAL CONNECTIONS.....	6
1.4.1	Lon Talk.....	6
1.4.2	Optional Network Interface with Isolated Digital Pulse Input (Di3)	7
1.5	NETWORK ADDRESSING.....	10
1.5.1	LonWorks Network Addressing	10
1.6.	COMMISSIONING THE FLOW DISPLAY	10
1.6.1	Service Pin LED States.....	10
1.7	LonWorks XIF FILES	10
1.7.1	Output Network Variables	10
1.7.2	Integer Format Output Network Variables.....	11
1.7.3	Input Network Variables.....	12
1.7.4	Node Object Network Variables	12
1.7.4.1	nviRequest.....	12
1.7.4.2	nvoStatus.....	13
1.7.5	Resetting Totals via the Network.....	13
1.7.6	Rollover of Totals	14
2.0	NETWORK TROUBLESHOOTING TIPS	15
2.1	TROUBLESHOOTING	15

APPENDIX

A-1	D-100 FLOW DISPLAY PROCESSOR BOARD
A-2	PHOTO OF LON BOARD
A-3	D-100 FLOW DISPLAY MOTHER BOARD POWER SUPPLY BOARD
A-4	INTEGER FORMAT OUTPUT NETWORK VARIABLES

SECTION 1: INTRODUCTION

1.1 PURPOSE OF THIS GUIDE

The purpose of this guide is to provide installation and commissioning procedures and basic operating and servicing instructions for the ONICON D-100 Flow Display.

1.2 TYPICAL D-100 FLOW DISPLAY

The D-100 is a totalizing display module that provides a local indication of liquid, gas or steam flow rate and total data. It can also be provided with an optional LonWorks serial interface to communicate data to the building control network.

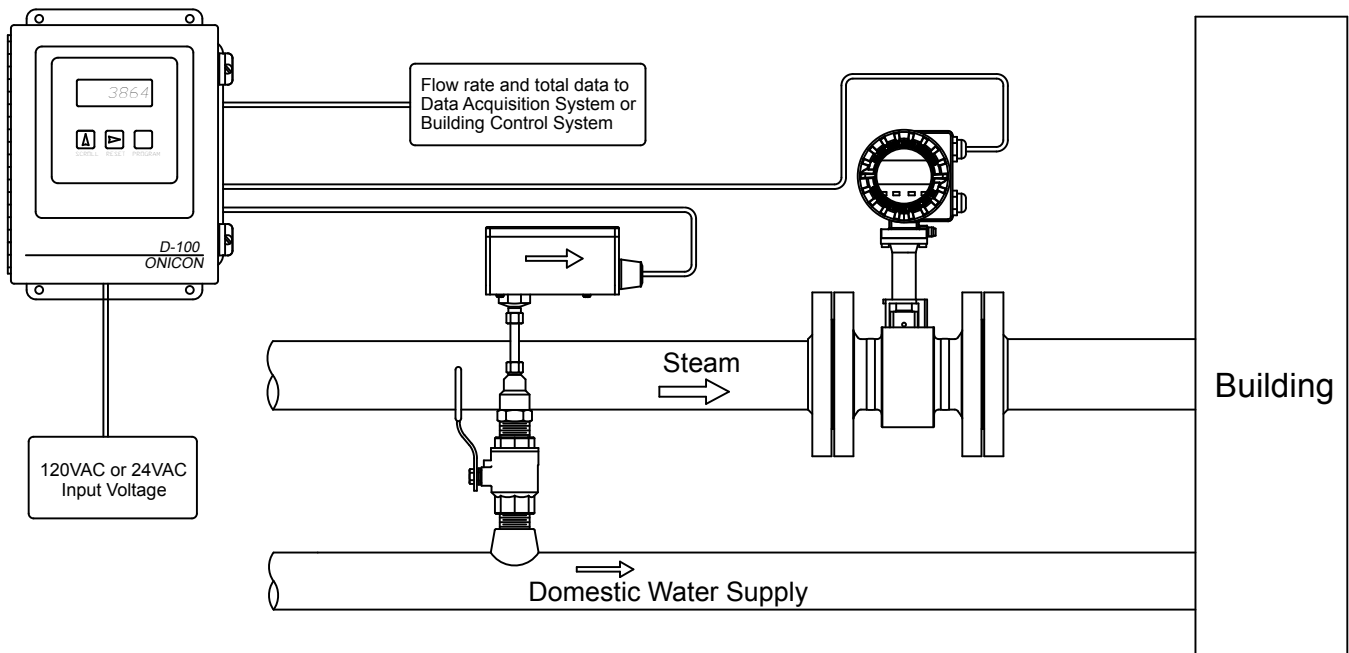

1.3 SPECIFICATIONS

LON TALK NETWORK INTERFACE

Twisted Pair / Free Topology

Transceiver: TP/FT-10F, 2-wire, non-polarized, transformer isolated connection

Device Address: 48-bit Neuron ID

Communications Rate: 78 kbps

Termination: None provided

Maximum Lead Length: 1640 ft (500 m) free topology

1.4 NETWORK SIGNAL CONNECTIONS

1.4.1 Lon Talk

Lon Talk, 2-wire serial output connections are connected to terminal T1 as shown. Do not exceed 4.4 in-lb (0.5 Nm) of torque when tightening.



CAUTION

Only qualified service personnel should make connections between the D-100 Flow Display and the user's external equipment. ONICON assumes no responsibility for damage caused to the external equipment as a result of an improper installation.

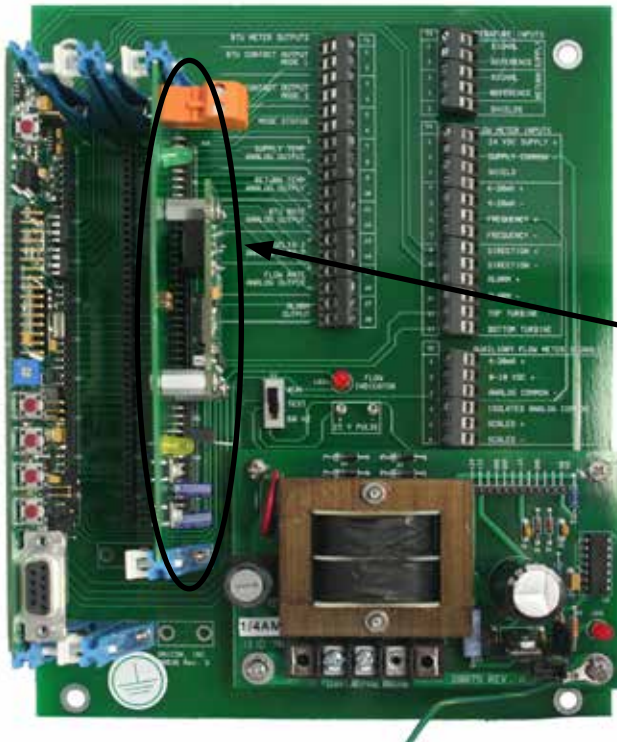

CAUTION

Incoming and outgoing cable shield wires should be connected together, but must not be connected to the display.

1.4.2 Optional Network Interface With Isolated Digital Pulse Input (Di3)

The D-100 Display can be provided with an digital pulse input for totalizing pulse outputs from external devices such as water or gas meters. Pulses are accumulated in an internal register, and the totalized value is available on the network. This register can be zeroed via the network. The maximum register total is 9,999,999. The register will rollover to zero when this value is exceeded.

If the digital pulse input option was ordered at the same time the display was ordered, it will arrive fully configured and ready to use. If it was ordered after the display was delivered and is being installed as a field upgrade, it may be necessary to configure the pulse input. The information is required to configure the input provided below and on the following pages:

The input pulse must meet the following criteria:

1. Frequency input range, 50 Hz maximum
2. 10 millisecond minimum pulse duration

Input Pulse Definition:

In order to configure the communications card digital pulse input, you must first determine which type of pulse your meter produces. The allowable types of input pulses are described on the following pages. Based on the type of pulse, set the selector switch (S1) on the communications circuit board (Fig. 1) to the correct setting.

Fig. 1

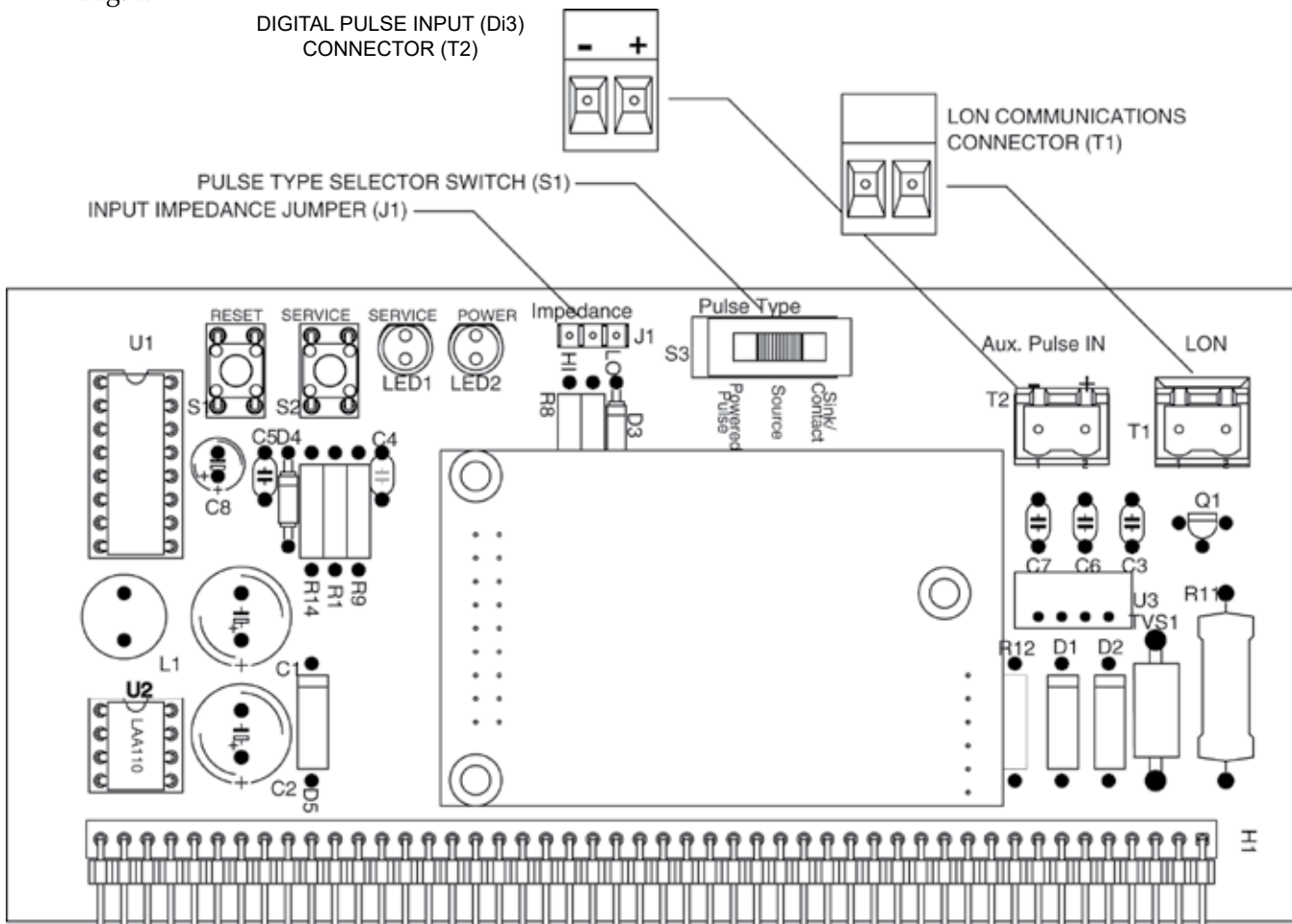

Powered Pulse:

This type of output refers to a pulse which has an associated voltage with it (see Fig. 2). Set the selector switch, S1 to Pwr'd Pulse. The allowable voltage range is 5-24 VDC. The input impedance is set at the factory to be 11 KOHM via the impedance selector jumper (J1, see Fig. 1). A lower impedance, 3 KOHM can be selected if required by the instrument providing the pulse output. Consult the instrument manufacturer or ONICON if you are uncertain as to the proper jumper selection.

Fig. 2

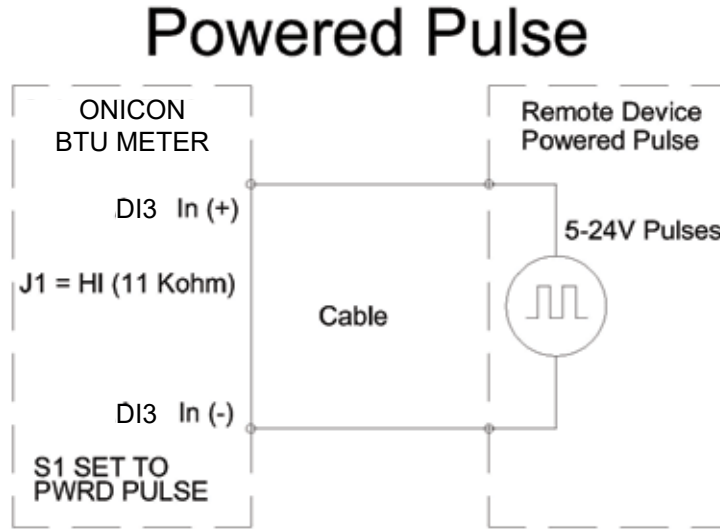

Open Collector (Sourcing):

This type of output refers to an open Collector Switch configured for a sourcing function (see Fig. 3). Set the selector switch, S1 to SRC. The switch must be rated for at least 20 mA at 20 VDC.

Fig. 3

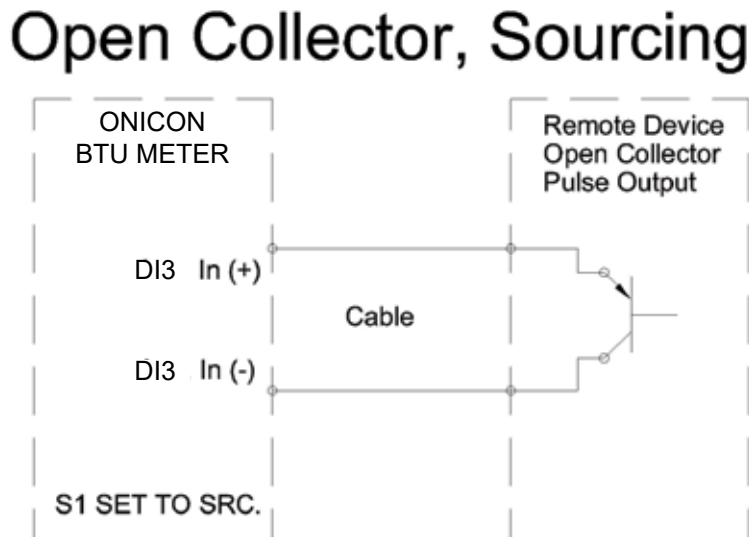

Open Collector Sinking or Dry Contact:

This type of output refers to an open collector switch configured in a current sinking arrangement or a dry contact switch (see Fig. 4 and 5). Set the selector switch, S1 to Sink. In either case, the switch must be rated for at least 20 mA at 20 VDC.

Fig. 4

Open Collector, Sinking

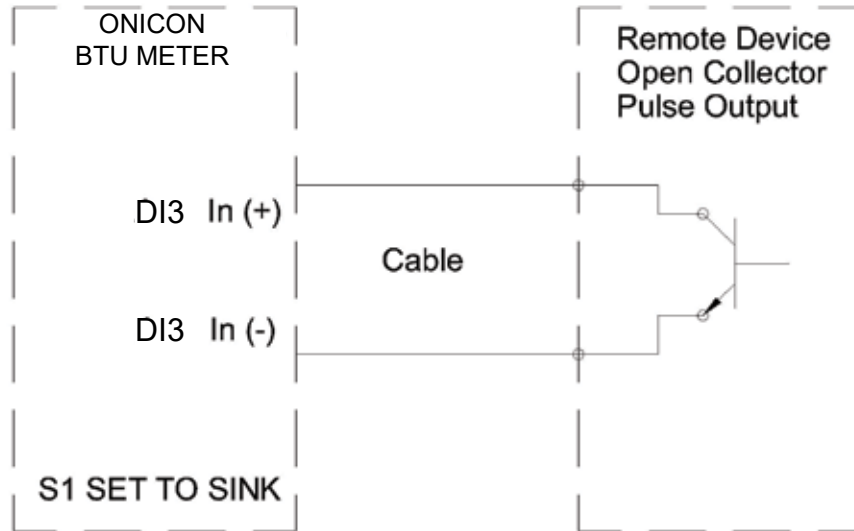
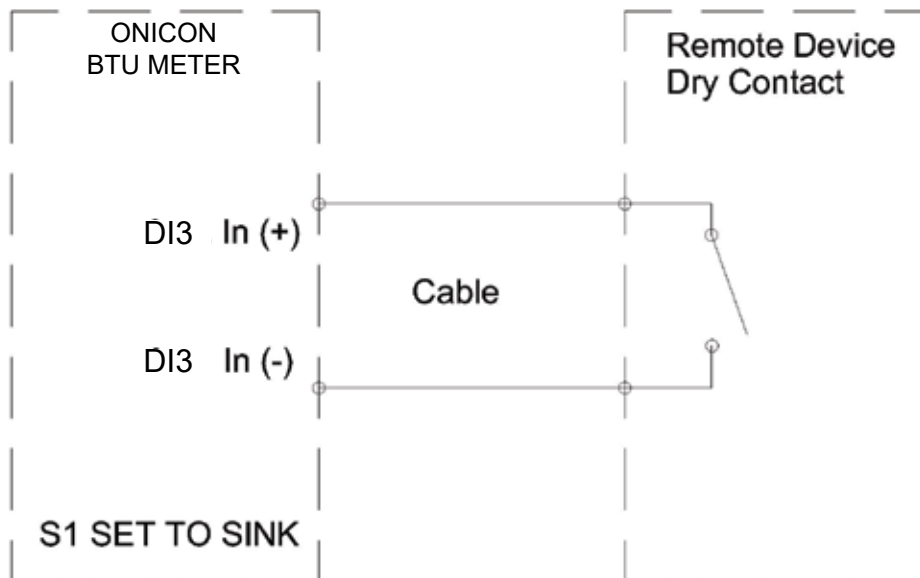

Fig. 5

Contact Closure



1.5 NETWORK ADDRESSING

The display contains two microprocessors, the D-100 board processor and the Echelon TP/FT-10F transceiver with its Neuron processor. The TP/FT-10F transceiver is located on the LON board. The two processors communicate with each other using a serial channel. This serial channel device address is fixed at 017 and cannot be changed.

1.5.1 LonWorks Network Addressing

Every Neuron processor has a unique 48 bit address known as the Neuron ID. This address is generally used as the Node ID. It is combined with the Domain ID and Subnet ID to form the device address. In most installations, the device address is created dynamically by the network.

1.6 COMMISSIONING THE FLOW DISPLAY

Pressing the Service Pin on the LON board (see Appendix 2) generates a service pin message on the network. The message contains the Neuron ID and the standard program identifier (SPID). The network configuration tool then maps the D-100 Neuron ID into the domain/subnet/node ID addressing scheme for the network, creating the device address.

1.6.1 Service Pin LED States

The yellow service pin LED indicates the status of the Lon Talk network connection.

- LED blinking at ½ Hz rate indicates that the meter is in an decommissioned state.
- LED off indicates that the meter is commissioned and operating normally.

1.7 LONWORKS XIF FILES

Each D-100-LON Flow Display is shipped with a diskette or CD containing the XIF file. It also contains the Neuron executable file in various formats and documentation describing the network variables in detail.

1.7.1 Output Network Variables

The D-100-LON Flow Display transmits data to the network using Standard Network Variable Types (SNVTs). Volume flow rate, and volume total are provided in floating point format.

Display operating mode and mode status information is provided in ASCII character format.

The floating point output network variables are described in the table on the next page. Column 1 contains a brief description of the network variables. Column 2 contains the network variable names. Column 3 contains the Lon SNVTs used for each variable. Column 4 contains the engineering units, and column 5 contains the valid range for each variable.

Floating Point Output Network Variables				
Description	Variable Name	SNVT Name	Engineering Units	Valid Range
Flow (volume) rate	nvoVolRateLf	SNVT_flow_f	Liters/Sec	0 to 10 ¹²
Flow (volume) total -1	nvoVol1Lf	SNVT_vol_f	Liters	0 to 10 ¹²
Flow (volume) total -2	nvoVol2Lf	SNVT_vol_f	Liters	0 to 10 ¹²
*Supply temperature	nvoSupplyTempf	SNVT_temp_f	° C	-17.778 to 148.889
*Return temperature	nvoReturnTempf	SNVT_temp_f	° C	-17.778 to 148.889
*Energy rate	nvoEnrRateWf	SNVT_power_f	Watts	0 to 10 ¹²
*Displayed energy rate	nvoDispEnrRatef	SNVT_count_f	*See note	0 to 10 ¹²
*Energy total -1	nvoBTU1f	SNVT_BTU_f	Btu	0 to 10 ¹²
*Displayed energy total-1	nvoDispEnergy1f	SNVT_count_f	*See note	0 to 10 ¹²
*Energy total-2	nvoBTU2f	SNVT_BTU_f	Btu	0 to 10 ¹²
*Displayed energy total-2	nvoDispEnergy2f	SNVT_count_f	*See note	0 to 10 ¹²
Auxiliary pulse input (Di3)	nvoAuxIn1	SNVT_count_f	None	0 to 10 ¹²

*These network variables are present but not used by the standard D-100. The present value for these variables will be zero.

The ASCII character status output network variables are described in the table below. Column 1 contains a brief description of the network variables. Column 2 contains the network variable names. Column 3 contains the Lon SNVT used for each variable. Column 4 contains the ASCII single characters that may be transmitted by the meter along with a description of what they indicate.

ASCII Status Output Network Variables			
Description	Variable Name	SNVT Name	Valid ASCII Characters*
Meter operating mode indicator	nvoMeterMode	SNVT_char_ascii	S = Single mode (83) D = Dual mode (68) B = Bidirectional mode (66)
Mode status indicator	nvoModeStatus	SNVT_char_ascii	N = Communication lost (78) Z = Communication restored waiting for update (90) H = Heating mode (mode 1) (72) C = Cooling mode (mode 2) (67) F = Forward flow (mode 1) (70) R = Reverse flow (mode 2) (82)

* Systems that are not set to decode ASCII characters will display the decimal equivalent. These values are shown in parentheses.

1.7.2 Integer Format Output Network Variables

ONICON provides rate and total data to the network in integer format for systems that cannot accept the floating point data. Refer to Appendices 3 and 4 for information on the use of integer format SNVTs.

1.7.3 Input Network Variables

The D-100-LON Flow Display receives remote commands to reset totals from the network using Standard Network Variable Types (SNVTs). The input network variables are in ASCII format. They are used to zero the flow and auxiliary pulse totals transmitted in the output variables listed in section 1.7.1.

The ASCII character reset input network variables are described in the table below. Column 1 contains a brief description of the network variables. Column 2 contains the network variable names. Column 3 contains the Lon SNVT used for each variable. Column 4 contains the ASCII single characters that must be transmitted to the meter along with a description of what they indicate.

ASCII RESET INPUT NETWORK VARIABLES

Description	Variable Name	SNVT Name	Valid Characters*
Reset Energy-1**	nviResetBTU1a	ANVT_char_ascii	Write an ASCII 1 (49) to reset the selected total. Once the total has reset, change the value to back to ASCII 0 (48).
Reset Volume-1	nviResetVol1a	SNVT_char_ascii	
Reset Energy-2**	nviResetBTU2a	SNVT_char_ascii	
Reset Volume-2	nnviResetVol2a	SNVT_char_ascii	
Reset Auxin1 (Di3)	nviResetAuxIn1a	SNVT_char_ascii	
*Systems that are not set to decode ASCII characters will use and display the decimal equivalent. These values are shown in parentheses. ** These variables are present but not used by the standard D-100.			

1.7.4 Node Object Network Variables

The D-100 LON Flow Display node object utilizes one output network variable and one input network variable. These are described in the table below.

NODE OBJECT NETWORK VARIABLES

Description	Variable Name	SNVT Name
Node object control input	nviRequest	SNVT_obj_request
Node object response output	nvoStatus	SNVT_obj_status

1.7.4.1 nviRequest

Five input variable requests have been implemented. These are listed in the table on the next page. Three of the requests are mandatory functions. They are Normal, Update Mask and Report Mask. The other two are used to reset totals in the Btu meter. They are Reset and Clear Reset.

The requests can be used on the node object or on selected function blocks. The tables on the next page describe the requests and the function blocks associated with totals in the display.

NODE OBJECT REQUESTS

Node Object Requests	Function Blocks Affected	Comments
RQ_NORMAL	0-27	This request clears the status registers. Function block 0 clears all function block status registers. Selecting function blocks 1- 27 only clears the selected status register.
RQ_UPDATE_MASK	0-27	This request updates the selected status register.
RQ_REPORT_MASK	0-27	This request displays the available Object Status functions.
RQ_RESET	0, 3, 6, 17, 21, 27	This request zeroes the various flow, energy and auxiliary pulse totals. If the Object ID 0 request RQ_RESET is selected then all totals are cleared. If the Object ID of 3, 6, 17, 21 or 27 RQ_RESET is selected then only the appropriate total is cleared.
RQ_CLEAR_RESET	0, 3, 6, 17, 21, 27	This request clears reset status flags. Object ID of 0 clears all "reset_complete" flags. Object IDs 3, 6, 17, 21, 27: Clears the selected "reset_complete" flags.

SELECT FUNCTION BLOCKS, DISPLAY TOTALS & DISPLAY OPERATING MODES

Functional Block	Flow Display Total	Flow Display Operating Mode		
		Single	Dual	Bidirectional
3	Flow (volume) - 1	Heat or Cool	Heating	Forward Flow
6	Flow (volume) - 2	Inactive	Cooling	Reverse Flow
27	Auxiliary Pulse (Di3)	Active	Active	Active

1.7.4.2 nvoStatus

Six status object functions are mechanized to report status information to the network. These are listed in the table below. The table also lists function blocks associated with each status flag.

nvoStatus Object Functions	Functional Blocks
object_id	All
invalid_id	All
invalid_request	All
comm_failure	0
report_mask	All
reset_complete	0, 3, 6, 17, 21, 27

1.7.5 Resetting Totals via the Network

Totals are held in non-volatile memory within the display. Each total (flow or auxiliary input) has a corresponding output variable that transmits the information from the display to the network. There are two ways to remotely reset totals in the display. This can be done using individual input variables to command the display to reset specific totals or it can be done using the nviRequest variable. Using nviRequest allows you to reset each total individually or all totals simultaneously with one command. See sections 1.7.3 and 1.7.4.1 for specific instructions on how to reset totals.

1.7.6 Rollover of Totals

The totals stored in the flow display memory will roll over to zero when the maximum count is exceeded. When this occurs, the network totals will also roll over to zero. The point at which the rollover occurs is a function of the displayed engineering units and multipliers programmed into the display.

The examples below show the rollover point in the engineering units transmitted by the network variable (SNVT) for common totals shown on the D-100 Flow Display.

VOLUME TOTAL

D-100 Display Engineering Units	D-100 Display Multiplier	LonWorks SNVT and Transmitted Engineering Units	Maximum Total Transmitted Over the Network
Gallons	X 100	SNVT_vol_f – Liters	3,785,411,621 Liters
Liters	X 1000	SNVT_vol_f – Liters	9,999,999,000 Liters
M ³	X 1	SNVT_vol_f – Liters	9,999,999,000 Liters

SECTION 2.0: NETWORK TROUBLESHOOTING TIPS

2.1 TROUBLESHOOTING

NOTE: Also refer to the COMMISSIONING GUIDE located on the preceding pages.

REPORTED PROBLEM	POSSIBLE SOLUTIONS
For turbine meters - No Flow Signal (while hydronic system is active)	<ul style="list-style-type: none"> • Verify 24 VDC supply voltage to the flow meter. • For insertion meters, verify the flow meter is correctly inserted into the pipe (using depth gage). • For insertion meters, verify that the flow meter electronics enclosure is parallel with the pipe. • Verify correct wiring to the flow meter (see wiring diagram). • For turbine meters, check turbine(s) for clogging due to debris. • If none of the above, check hydronic system to ensure that flow is really present in the line. • NOTE: Flow meter function cannot be verified by blowing on the turbine(s). The sensing system requires a conductive liquid to operate. You can test it by swirling it around in a bucket of water and looking for the flow indicator LED to flash at the D-100.
Displayed flow rate too high or too low	<ul style="list-style-type: none"> • Verify pipe size. Contact ONICON if pipe size is different from calibration tag. • For insertion meters, verify that meter is inserted correctly into the pipe (using depth gage). • For insertion meters, verify that the flow meter electronics enclosure is parallel with the pipe. • For dual turbine meters, confirm that both turbines produce pulses. • For turbine meters, check turbine(s) for debris. • Verify supply voltages (to display and flow meter).
Device is not communicating with the Lon Talk network.	<ul style="list-style-type: none"> • What is the state of the service pin LED? • Is it flashing? A flashing service pin LED indicates that the Lon module has not been commissioned. • Is it off? A service pin LED that is off indicates that the Lon module is commissioned and operating normally.
Communications with the Lon Talk network is intermittent.	<ul style="list-style-type: none"> • Is the network properly terminated? The Lon TP/FT bus can be terminated in 2 different ways. • A single RC filter can installed at any point on a free topology network. A dual termination scheme is used with 2 RC filters installed at the ends of bus networks. Refer to the drawings below for details. • What type of cable is used to wire the network? TP/FT networks should only use twisted shielded pair cable. (Belden 85102 or equiv.)

For technical assistance, contact ONICON Incorporated at (727) 447-6140.

APPENDIX

A-1 D-100 FLOW DISPLAY PROCESSOR BOARD

A-2 PHOTO OF LON BOARD

A-3 D-100 FLOW DISPLAY MOTHER BOARD POWER SUPPLY BOARD

A-4 INTEGER FORMAT OUTPUT NETWORK VARIABLES

D-100 FLOW DISPLAY PROCESSOR BOARD

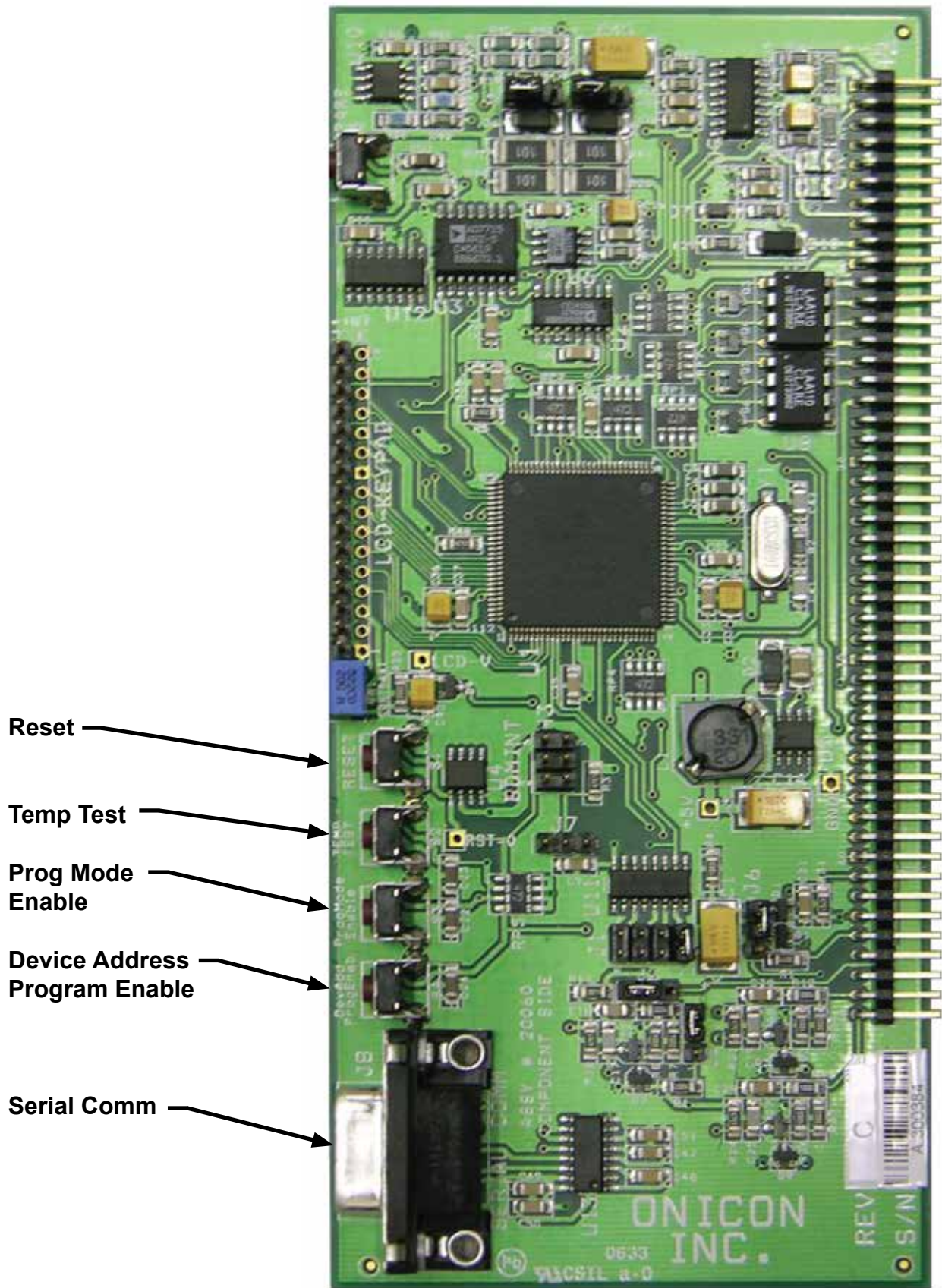

- Reset
- Temp Test
- Prog Mode Enable
- Device Address Program Enable
- Serial Comm

PHOTO OF LON BOARD



D-100 FLOW DISPLAY MOTHER BOARD POWER SUPPLY BOARD



24 VAC - 1 Amp Slo-Blo, 3AG Fuse

120 VAC - 1/4 Amp Slo-Blo, 3AG Fuse

240 VAC - 1/8 Amp Slo-Blo, 3AG Fuse

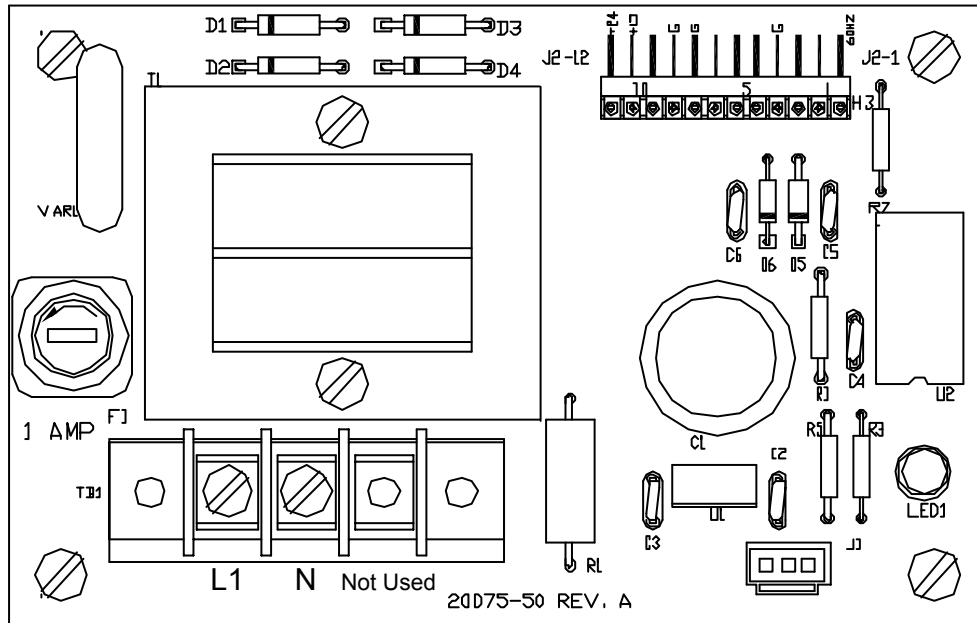

INTEGER FORMAT OUTPUT NETWORK VARIABLES



Integer format output variables are limited to 2 bytes of data. For this reason, the maximum number that can be transmitted in this format is 65,535. Values for both rate and total data will often exceed this limit.

Rate Variables

The integer output network variables for volume rate are described in the table below. Column 1 contains a brief description of the network variables. Column 2 contains the network variable names. Column 3 contains the Lon SNVTs used for each variable. Column 4 contains the engineering units and column 5, the valid range for each variable.

Integer Output Network Variables				
Description	Variable Name	SNVT Name	Engineering Units	Valid Range
Flow (volume) rate	nvoVolRateLi	SNVT_flow	Liters/Sec	0 to 65535
Mode status indicator	nvoModeStatus	SNVT_char_ascii		
*Supply temperature	nvoSupplyTempi	SNVT_temp_p	° C	-17.778 to 260.0
*Return temperature	nvoReturnTempi	SNVT_temp_p	° C	-17.778 to 260.0
*Delta temperature	nvoDeltaTempi	SNVT_temp_diff_p	° C	-327.68 to 327.66
*Energy rate	nvoEnrRateKWi	SNVT_power_kilo	KWatts	0 to 65535

* These network variables are present but not used by the standard D-100.

Total Variables

The integer output network variables for total are described in the table below. Column 1 contains a brief description of the network variables. Column 2 contains the network variable names. Column 3 contains the Lon SNVTs used for each variable. Column 4 contains the engineering units and column 5, the valid range for each variable.

Please note that while the floating point variable for FLOW total is transmitted in liters, the integer network variable for FLOW total is transmitted in kLiters. This is done to increase the maximum total that can be transmitted via the integer variable. Total(s) must be reset before the accumulated value exceeds 6553.5 kliters using nviResetVol1a and/or nviResetVol2a. If this is not done, nvoVol1KLi and/or nvoVol2KLi will over range and continue to indicate 6,553.5 kliters (1,731,252 gallons) until the D-100's internal total rolls over to zero.

A separate integer SNVT is also available to transmit flow totals in liters. This variable is only used in special small pipe applications as the maximum total it can accumulate is only 65,535 liters (17,312 gallons) before it must be reset.

Integer Output Network Variables				
Description	Variable Name	SNVT Name	Engineering Units	Valid Range
* Flow (volume) total -1	nvoVol1Li	SNVT_vol	Liters	0 to 65535
Flow (volume) total -1	nvoVol1KLi	SNVT_vol	KLiters	0 to 6553.5
* Flow (volume) total -2	nvoVol2Li	SNVT_vol	Liters	0 to 65535
Flow (volume) total -2	nvoVol2KLi	SNVT_vol	KLiters	0 to 6553.5
Energy total -1**	nvoKiloBTU1i	SNVT_btu_kilo	KBtu	0 to 65535
Energy total -1**	nvoMegaBTU1i	SNVT_btu_mega	MBtu	0 to 65535
Energy total -2**	nvoKiloBTU2i	SNVT_btu_kilo	KBtu	0 to 65535
Energy total -2**	nvoMegaBTU2i	SNVT_btu_mega	MBtu	0 to 65535

* Special small pipe volume total variables

** These network variables are present but not used by the standard D-100.